

Structural timber buildings fire safety in use

Volume 1 - Pattern Book systems

STA fire safety research project | Version 3.1 | December 2024



Copyright and limitations of the Pattern Book

The Structural Timber Association's objective in developing this Pattern Book was to provide resilient evidence-based solutions, in a way that has never previously been done in the UK.

This Pattern Book provides clarification of performance on different timber frame systems. It is the specifiers obligation that when seeking confirmation of the fire resilience of the systems as describe herein it is precisely the same as that being proposed and is suitable at the point of use. It is incumbent on the STA member to confirm this of their systems, and to provide additional tested information should their system differ in any way.

All data provided is for use by competent persons, from the structural timber industry and built environment, who understand the sector they work in. While this document has been prepared in good faith and all reasonable efforts have been made to ensure its adequacy and accuracy, no representation, warranty, assurance or undertaking (express or implied) is or will be made, and no responsibility or liability is or will be accepted by the STA.

The information contained within this document is held under STA copyright. STA does not permit, under copyright law, any organisation to publicly present or reproduce any information contained within the report in part or in full.

STA Assure

Please note that timber frame systems performance declarations only apply when supplied and/or erected by STA member companies, operating under the STA Assure Quality Scheme. They do not apply to non-member companies engaged in the supply and install of timber frames, regardless of any similarity of systems.

© December 2024, Structural Timber Association

Document revision history

v1.1 March 2020

Original document published.

v1.2 June 2020

Stakeholder support from Scottish Government Building Standards Division added to P5.

v1.3 July 2020

Stakeholder support from NHBC added to P5.

v2.0 March 2021

Updated to remove patterns which were expected to be available late 2020. For consistency the single leaf party wall roof spandrel (showing Fermacell) in v1.3 remains valid, but will be moved to STA Pattern Book Volume 3. Other specific changes are to Part 4 roof spandrel systems 10 and 11 of v1.3 which have been removed. Also added: links to Truss Rafter Association and reference to Engineered Wood Products activity, clarification of mineral wool density and the role of BRE Global in the reviewing process.

v2.1 August 2022

Clarification of exposure to fire testing.

v2.2 September 2022

Part 4 now floor patterns and includes REI30 metal web joist and I-joist solutions. Recommendations for the loading of floors in fire resistance testing with an explanation about how the load influences the joist design.

v2.3 May 2023

Correction to WT7 robust details wall compliance.

v2.4 February 2024

Updates to 'Overview' and 'Research and testing' sections, limited to 11m upper floor level height solutions, addition of three new floor systems, plus correction to equation on p44.

v2.5 February 2024

Correction to metal web joists depth.

v3.0 April 2024

Document revised, six new wall systems added, new naming protocol for existing systems

v3.1 December 2024

Two new wall systems added, minor clarifications to previously existing wall and floor systems and generic roof spandrel systems (section 10) amended

Contents

1. Overview	
1.1 Introduction	6
1.2 Stakeholder engagement.....	7
1.3 Collaborations	8
1.4 Acknowledgements	9
1.5 Purpose and scope of the Pattern Book	11
2. Research and testing	
2.1 Background.....	12
2.2 Research.....	13
2.3 EN fire resistance testing.....	13
2.4 Gap analysis.....	14
2.5 Timber frame wall systems EN test methodology and approach.....	16
2.6 Future third party EN fire resistance testing	18
2.7 Pattern Book - tested systems.....	18
3. Generic external wall systems (REI30)	
3.1.1 EW30-GW-01 REI30 external wall	19
3.1.2 EW30-GW-02 REI30 external wall	21
3.1.3 EW30-GW-03 REI30 external wall	23
3.2.1 EW30-PIR-01 REI30 external wall	25
3.2.2 EW30-PIR-02 REI30 external wall	27
3.2.3 EW30-PIR-03 REI30 external wall	29
4. Generic external wall systems (REI60)	
4.1.1 EW60-GW-01 REI60 external wall	31
4.1.2 EW60-GW-02 REI60 external wall	33
4.1.3 EW60-GW-03 REI60 external wall	35
4.2.1 EW60-PIR-01 REI60 external wall	37
4.2.2 EW60-PIR-02 REI60 external wall	39
5. Generic internal loadbearing wall systems (REI30)	
5.1 IW30-V-01 REI30 internal wall.....	41
6. Generic internal loadbearing wall systems (REI60)	
6.1 IW60-V-01 REI60 internal wall.....	43

7. Generic party wall systems (REI60)	
7.1 PW60-GW-01 REI60 party wall	45
7.2 PW60-GW-02 REI60 party wall	47
8. Generic floor systems (REI30)	
8.1 IF30-IJ-V-01 REI30 intermediate floor, I-joist.....	49
8.2 IF30-IJ-V-02 REI30 intermediate floor, I-joist.....	51
8.3 IF30-IJ-V-03 REI30 intermediate floor, I-joist.....	53
8.4 IF30-MJ-V-01 REI30 intermediate floor, metal web joist.....	55
9. Generic floor systems (REI60)	
9.1 CF60-IJ-GW-01 REI60 compartment floor, i-joist	57
9.2 CF60-MJ-GW-01 REI60 compartment floor, metal web joist	59
10. Generic roof spandrel systems (EI60)	
10.1 PWS60-TL-V-01 EI60 party wall spandrel panel with cover strips	61
10.2 PWS60-TL-V-02 EI60 party wall spandrel panel with intumescent strips	63
11. Additional systems	
11.1 Timber roof truss systems	65
11.2 Timber wall systems.....	66
12. Supporting appendices	
12.1 EN 1365-1:2014 fire resistance testing for walls	67
12.2 EN 1365-2:2014 fire resistance testing for floors	70
12.3 Future systems approvals process flow chart	74

1. Overview

1.1 Introduction

Timber frame construction is a traditional method of building, with a proven track record of mainstream compliance and longevity. It is widely recognised as the offsite construction system of choice, offering many benefits, including low carbon, cost effective, quality, speed and regulatory compliance.

Fire safety in use affects all forms of construction. All buildings must be designed to comply with the fire safety functional requirements of the building regulations, as a minimum standard. The STA has invested in an industry leading, fire in use research project to test commonly used timber frame wall, floor and roof make ups used in the UK marketplace. This work has been done in partnership with CSIC, University of Edinburgh, BRE Global, RISE and with the kind financial sponsorship of Swedish Wood, Scottish Forestry, Engineered Wood Products Committee and STA manufacturing members.

In addition, the STA commissioned the University of Edinburgh and BRE Global to undertake research into various fire related matters associated with timber frame construction and material/system testing, providing further confidence in the Pattern Book produced and its use in the UK marketplace.

The Pattern Book output is part of the STA's library of fire in use best practise guidance. The STA library of documentation provides comprehensive guidance, information and recommendations on system specifications and good practise principles when using timber frame construction.

The STA believes this Pattern Book of EN tested systems to be the first of its kind, not seen in the timber frame sector before. The EN tested systems and good practice recommendations provide a comprehensive package of information for the design, specification and construction of timber frame buildings that are acceptable under the Building Regulation statutory guidance for fire resistance time periods.

This information has been supported and endorsed by several industry and government stakeholders, providing deemed to satisfy style solutions and a unique reference library of information for clients, members and specifiers to use, with confidence.

The information will be regularly reviewed and updated by the STA Technical Committee and Board and is free to download from the STA website www.structuraltimber.co.uk

We hope you find the information provided, both functional and beneficial.



Chief Executive

Structural Timber Association

Company Registration Number: 3862401

Report made possible with funding from



In partnership with



1.2 Stakeholder engagement

One of the founding principles of the STA research and fire testing project, was to ensure the Pattern Book of systems created, was relevant to the UK marketplace, reflecting commonly used systems, with the recognition of key industry authorities and government stakeholders, to ensure the information was credible and reliable.

Throughout the project industry bodies such as NHBC, MD Warranty Inspection Services Ltd and LABC have been kept abreast of progress, as well as Government Building Regulatory Authorities such as SGBSD and MHCLG/DLUH/BSR. The outputs from the project have been peer reviewed by Milner Associates or technical submission of data for peer review by BRE Global, to ensure they are technically robust and validated from independent experts.

All stakeholder organisations welcomed the first 2020 edition of this guidance.



1.3 Collaborations

The STA continue to collaborate with other industry groups, who have been undertaking similar EN fire resistance testing programmes, complimentary to the STA's work.

This is related to:

1. Timber floor and roof systems, applicable to both masonry and timber frame methods of construction.
2. Additional timber frame wall make-ups, commonly used in Ireland, which are outside of the UK building regulatory system.

These EN testing programmes were organised by the following organisations and supply chains:

- Timber floors - Engineered Wood Products Committee and supplier members
- Timber roofs - Trussed Rafter Association and supplier members
- Timber frame walls - Irish Timber Frame Manufacturers Association and Department of Environment, Ireland.

All fire resistance testing has been undertaken to the same test standard, BS EN 1365-1:2012 (walls) and BS EN 1365-2:2012 (floors). The test information continues to be evaluated between the STA, organisations and suppliers, in a collaborative way, with the intent of increasing the number of systems contained in this Pattern Book as part of future updates.



1.4 Acknowledgments

Construction Scotland Innovation Centre

Scotland's construction innovation centre focused on the built environment, supporting research and development into accelerating industrialisation, digital transformation, culture change and building sustainably, to drive transformational change across the construction industry.

Swedish Wood

Europe's leading timber promotional organisation, supporting research and development, into timber technology and use in the UK and overseas.

Scottish Forestry

The UK's leading forestry organisation, supporting the development of home grown timber and related technologies.

STA Manufacturing Members

STA manufacturing members, governed under the STA Assure Standard, for the design, fabrication and installation of timber frame buildings in the UK.

Advanced Timber Craft (Kudos) Ltd	Harmony Timber Frame Ltd	Rob Roy Homes (Crieff) Ltd
Alexanders Timber Design Ltd	Horton Timber Homes Ltd	Robertson Timber Engineering Ltd
Angus Homes Ltd	Hybrid Houses Ltd	Scotframe Timber Engineering Ltd
Bartram Timber Frame Ltd	Kalite Timber Frames Ltd	Seven Oaks Modular Construction Ltd
Castleoak Timber Frame Ltd	Kingspan Timber Solutions Ltd	Shire Timber Structures Ltd
CCG (OSM)	Leadon Timber Frame Ltd	Southern Timber
City Building (Glasgow) LLP	LF FastHouse Ltd	Southern Timber Frame Ltd
Cornwall Timber Build Ltd	Local Homes (Accord)	Space4
Cygnum Building Offsite	Lowfield Timber Frame Ltd	Sticx Ltd
Deeside Timberframe Ltd	Maple Timber Frame Merronbrook Ltd	Sydenhams Timber Engineering Ltd
Donaldson Timber Systems Ltd	MBC Timber Frame UK Ltd	Target Timber Systems Ltd
ETF (Northern) Ltd	MTE (Leicester) Ltd	Taylor Lane Timber Frame Ltd
Fforest Timber Engineering Ltd	Neatwood Homes Ltd	The Timber Frame Company
Fleming Buildings	Norscot Joinery Ltd	Thomas Armstrong (Timber) Ltd
Flight Timber Products Ltd	Oakworth Homes Ltd	Timber Frame It SE Ltd
Frame Homes / Frame UK Ltd	OFP Timber Framed Homes Ltd	Timber Frameworks (Alba) Ltd
Frame Technologies	Oregon Timber Frame Ltd	Truro Timber Frame Ltd
Frame-Tech Structures Ltd	PEC Timber Frame Ltd	Walker Timber Group
FrameWork Synergies Ltd	Pinewood Structures Ltd	

EWPC Joist Manufacturing Members

ITW Group Ltd	Metsä Wood UK Ltd	Steico UK Ltd
James Jones and Sons Ltd	Mitek UK Ltd	Wolf Systems Ltd
Masonite Beams Ltd	Staircraft Group Ltd	

Project team

The STA Board and members are indebted to the original project team and collaborators, who have spent significant time and effort developing and delivering this leading edge research and guidance project. Their sub-contracted and in-kind contributions will benefit the sector, clients and stakeholders. Their dedication, management and drive to complete this work has been unwavering, resulting in comprehensive information the sector can rely on with confidence for years to come. Ongoing project work is coordinated by the STA Safety Steering Group.

Project team (2019-2020)

Stewart Dalgarno, Stewart Milne Group

Dr Jamie McLean, University of Edinburgh

Martin Milner, STA Technical Advisor

Prof. Luke Bisby, University of Edinburgh

Sam Hart, Construction Scotland Innovation Centre

David Fleming, Walker Timber Group

Andrew Allison, Walker Timber Group

Robin Dodyk, Oregon Timber Frame

John Smith, Donaldson Timber Systems

James Beattie, Donaldson Timber Systems

Consultants and sub-contractors (from 2019)

Tom Lennon, BRE Global

Martin Milner, Milner Associates, Critical Friend Services

James Walker, Milner Associates, Technical Consultant

Alar Just, RISE, Peer Review

David Fleming, Flex Business Solutions

Warrington Fire, Fire Testing Services

BRE Global, Fire Testing Services

STA Safety Steering Group (2023-2024)

Andrew Orriss, Structural Timber Association

John Smith, Donaldson Timber Systems

Alan Robb, Benx Group

Richard Baldwin, Walker Timber Frame

Sam Dawe, Innovare Offsite

Martin Milner, Milner Associates

Gordon Megahy, Clancy Consulting

Mark Stevenson, Kingspan/consultant

1.5 Purpose and scope of the Pattern Book

The STA Fire Safety in Use Guidance provides a “suite of information” for use in the marketplace. Volume 1 is a Pattern Book of EN tested timber frame systems. The Pattern Book will evolve and grow as further systems are tested, validated and introduced. Volume 2 covers cavity barriers, providing technical information, compliance requirements and installation guidance on the correct fitting of cavity barriers. Future volumes will be developed and included within the suite of information. Items being considered for future volumes include for example, drylining specification and installation, and guidance on service penetrations.

The purpose of Volume 1: Pattern Book is to provide STA members, clients and specifiers with information on peer reviewed generic wall, floor and roof systems that are backed up by EN test evidence and supplementary research to create resilient fire safe solutions for timber frame buildings..

Information is presented in the form of a Pattern Book, similar to Robust Details acoustic detailing. All the STA tested wall and floor systems, in Parts 3 to 9 respectively, have been technically reviewed by Milner Associates in collaboration with a peer review by BRE Global and/or RISE.

The Pattern Book includes recommendations and guidance on the design, specification and installation of various commonly used systems within timber frame buildings in the UK. The information provided relates to fire resistance compliance of wall and floor assemblies.

The Pattern Book provides a platform to include additional systems in the future. Work is ongoing to include further elements of structure systems.

The Pattern Book does not cover bespoke or modified systems that differ from those tested.

Compliance of any system is the responsibility of the principle designer for the project/building. It is the legal duty of the principle designer to ensure regulatory compliance is demonstrated without the use of this Pattern Book. Fire resistance periods are given and it is the responsibility of the project designer to ensure the required fire resistance relevant to the project. Only people with a sound technical, design, construction and fire engineering knowledge from STA members, clients, designers, builders and specifiers of timber frame buildings, should use the Pattern Book.

This publication does not cover fire safety during construction, which is legislated for in the Construction (Design and Management) Regulations 2015. The Health & Safety Executive provides overarching guidance on this subject in their publication HGS168 Fire safety in construction. The STA has a significant library of information on fire during construction when using structural timber methods, which can be downloaded via www.structuraltimber.co.uk

2. Research and testing

2.1 Background

The Fire in Use Project started as a collaborative research project between the STA, the Construction Scotland Innovation Centre and The University of Edinburgh, supported by sponsorship funding from the Construction Scotland Innovation Centre, Swedish Wood, Scottish Forestry and a levy on STA manufacturing members.

The project goal was to produce a Pattern Book of generic EN tested timber frame wall, floor and roof systems to complement existing and new fire safety in use industry guidance. The outcome being to further enhance confidence in timber frame construction and provide a go-to reference manual for people to use. The project work has continued with added support from the EWPC. Ongoing work is taking place to add more solutions following a detailed review of submitted testing.

All information is freely available to STA members, clients, designers, specifiers, builders and industry stakeholders via STA website www.structuraltimber.co.uk. The Pattern Book will be reviewed periodically, by the STA Technical Committee and Board, with updates and amendments issued accordingly.

The project is ongoing and organised into four distinct, but connected work packages, running in parallel to gather the relevant data required for the Pattern Book.

1. The first stage was the completion of research into various aspects of timber fire safety and testing.
2. The second stage has been and continues to be the completion of a large programme of full-scale EN fire resistance testing.
3. The third stage has been and continues to be the collation of all research and test information for analysis, peer reviewed by Milner Associates in conjunction with BRE Global and/or RISE.
4. The final stage was the creation of the Pattern Book and engagement with stakeholders.



2.2 Research

A gap analysis was produced to ascertain the status of various historic and current fire safety in use design and test protocols and their relevance to the timber frame sector. This identified several key areas for further detailed research work to be undertaken to recalibrate current thinking and protocols on fire safety design and testing of timber frame systems suitable for current and future use.

The first area of research was material variability of plasterboard manufactured to BS EN 520:2004. This was conducted at The University of Edinburgh. The aim of this was to better understand plasterboard variability in the context of fire performance of finished wall systems. This research investigated Type A and F plasterboards available from three leading UK supply chains: British Gypsum, Siniat and Knauf.

The second element of research was on loading requirements for fire resistance testing of timber frame systems. A position paper has been produced to outline recommendations for the test loading of walls and floors when undertaking fire resistance testing. The position papers were produced by Milner Associates. This information provides a common playing field for load applications and a basis for system testing in the future.

A final element of research was to commission Milner Associates to gather all research and derive justifications and methodologies for the proposal of generic classifications for common materials and wall and floor make ups noted in Parts 3 to 9 and tested by STA. The focus was on Type A plasterboard, for presentation and peer review by BRE Global and/or RISE.

Milner Associates, working alongside BRE Global and RISE, were engaged by the STA to undertake a peer review of the fire research, including testing, results and materials.

STA has concluded that UK supplied Type A or Type F plasterboard as specified (BS EN520:2004) from British Gypsum, Siniat or Knauf is suitable for use in STA wall and floor systems listed in this Pattern Book.

2.3 EN fire resistance testing

1. Wall constructions

The STA have sponsored research to have tested the wall systems in this guidance intended to meet 30 and 60 minute minimum REI compliance requirements. These included external, load bearing and party wall configurations. Some of these tests were research related and repeat tests to validate work undertaken. This has yielded 13 timber frame wall make-ups commonly used in the UK timber frame marketplace. These systems are specified in more detail within Parts 3 to 7 of the Pattern Book.

All fire resistance tests were undertaken to EN 1365-1 test standard. A double socket was fitted within all external wall tests even though this is not a requirement of the test standard. Test loads were applied in line with the position paper developed as part of the early stage research (See Part 12) suitable for buildings up to 11m upper floor level. 15mm Type A plasterboards were used throughout, for the approved systems contained within the Pattern Book.

2. Floor constructions

For the floor systems, the STA has reviewed 75 fire test reports intended to meet 30 and 60 minute minimum REI compliance requirements. The fire tests used I-joists and metal web joists from different manufacturers supplying the UK market and has yielded six timber frame floor systems commonly used in the UK. These systems are specified in more details with Part 8 of the Pattern Book.

All fire tests were undertaken to EN 1365-2 test standard. Some tests made use of downlighters within the plasterboard and the companion STA publication 'Tested downlighters achieving REI30 minutes' provides a list of products known to have been tested or assessed as part of an REI30 floor assembly. For the fire resistance periods given, the floor systems must not be loaded beyond the design loads provided for each pattern, otherwise the project engineer must provide a separate load calculation using the appropriate stress index as provided by the chosen floor joist supplier.

In addition, the STA continues to collaborate with other test programmes to better understand the differing wall, floor and roof systems, used in the marketplace as proprietary or generic systems, with validated EN test information, for future inclusion within the Pattern Book.

3. Scope of fire tested solutions for timber frame structures

The EN tested systems are applicable for most common applications of timber frame buildings that are constructed in the UK under the Building Regulation compliance route adopting the national statutory guidance. The national statutory guidance that supports Building Regulations is to assist building designers in their decision making on relevant building types and relevant materials used. For fire testing, the statutory guidance provides routes to compliance with the Building Regulations adopting benchmark EN 1365 furnace tests for justification of fire resistance of walls, floors and roofs.

The building designer has three options to adopt in assessing and choosing a fire safety route for compliance for fire resistance.

Level 1 - General fire resistance classification to follow the requirements in statutory guidance.

Level 2 - Advanced guidance review adopting BS9991 (Fire safety in the design, management and use of residential buildings - Code of practice) that expands on the statutory guidance and may apply a risk-based approach by competent persons to take account of specific building and end user factors.

Level 3 - Fire engineering adopting standards such as BS 7974 and advanced fire design processes from large scale tests and industry understanding of fire behaviour.

It is for the building designer to decide if the fire resistance of the system selected from the information presented in this document is sufficient to demonstrate compliance with the fire safety strategy for the building.

2.4 Gap analysis

A gap analysis was completed by The University of Edinburgh in 2018 to identify key areas of interest in the design and construction of timber frame systems that were beneficial to target as part of this research project. This included reviewing historic and current BS and EN information, industry specific information often referred to and used in the marketplace and relevant academic research conducted by various UK and European universities, including Vaxjo University in Sweden and Edinburgh Napier University.

The gap analysis provided two major areas of interest for further investigation. These were:

1. Load ratios applied as part of BS and EN fire resistance test standards.
2. Plasterboard variability, benchmarking and thermal response.

Following the completion of the gap analysis, further detailed research was undertaken and completed to inform the testing programme to be undertaken and the final Pattern Book.

1. Load ratios - fire resistance testing

Milner Associates prepared an initial thought paper on historic BS load ratios and EN load reduction factors, to inform a load ratio workshop, held at The University of Edinburgh. Structural and fire engineers from multiple disciplines were gathered to discuss and determine appropriate load ratios to apply when undertaking the overall testing programme. Following the workshop, an STA position paper on load ratios was produced and test loadings calculated to EN standards for use in the tests.

The first seven systems tested as part of this research project were loadbearing elements tested to BS EN 1365-1:2012. The research noted that there are some differences between how BS standards and EN standards define "load ratio".

To avoid confusion and clarify these differences, a detailed STA position paper on load ratios was produced by Milner Associates to inform the load applied in each of the tests as given in Part 12.1. The acceptable load ratios for floors are different to walls and a separate methodology was developed by Milner Associates for use with floors, as given in Part 12.2. This was peer reviewed by BRE Global to ensure its appropriateness for use in the testing.

This information used to inform the physical testing and to engage stakeholders as part of the development of the Pattern Book. This will inform members as to the STA recommendations for the appropriate load ratios to apply, for those wishing to undertake fire resistance testing of their own systems or materials.

2. Plasterboard variability and benchmarking: EN 520:2004

Plasterboard is produced to BS EN 520:2004. This is a manufacturing standard that governs production processes and provides quality assurance. It is not a declaration of fire performance of the board. It is permissible under BS EN 520:2004 to have controlled variation in board production. This provides flexibility to manufacturers. It is therefore important to recognise this in EN fire resistance testing and subsequent declarations of performance, of any construction system tested.

Following the gap analysis, University of Edinburgh undertook a programme of plasterboard material variability tests, for a small sample of 15mm and 12.5mm Type A and Type F plasterboard procured and used in the UK. Type A boards were selected as the most commercially viable and commonly used boards. The STA wall testing programme focused on the use of 15mm Type A boards, in consideration of the test pass thresholds being targeted and the more onerous EN fire resistance test standard being adopted.

These experimental research tests provided indicative information on the thermal response and material variability of various plasterboards with the intent of benchmarking them. This research was used to inform the final makeup of the walls, test programme and the thermocouple data to be collected as part of the overall testing programme.

The material variability research testing consisted of an experimental test series undertaken at The University of Edinburgh with the purpose of understanding, quantifying and benchmark their thermal response. The purpose of this testing exercise was to understand the plasterboard variability of three UK supply chains - British Gypsum, Knauf and Siniat boards, commonly available in the UK market.

The main conclusions of the research were that there are small differences between the density and water content of the different plasterboards available on the market. In addition to this there can be slight differences between boards of the same brand manufactured in different batches or locations. The boards tested were all classified according to manufacturing standard BS EN 520:2004.

2.5 Timber frame wall systems EN test methodology and approach

STA testing program

The STA testing programme prioritised open panel timber frame external, loadbearing and party wall make ups commonly used in the UK marketplace, representing approximately 80% of the timber frame systems used.

It is recognised that there are a variety of more bespoke timber frame systems used in the marketplace. However due to finance, time and test laboratory availability, it was not feasible to test every permutation within this project.

The STA test programme was completed over three phases, with intermediate reviews and refinement incorporated as test outcomes were established and research data gathered.

The principal building designer and client, using bespoke timber frame systems, have a duty of care to ensure any bespoke systems being used are appropriately tested and compliant to the building regulations and functional standards.

Test standard

All EN fire resistance tests conducted were done in accordance with the test standard BS EN 1365-1:2012 for loadbearing walls. The decision to test in accordance with EN standards was taken to reflect the general movement towards the more onerous European test standards, as opposed to the current BS test standards, historically used in the marketplace. This test standard is applicable to both internal and external loadbearing walls. Tests were conducted to demonstrate compliance above the required REI30 or 60 minute functional standards required by the building regulations.

In September 2024 the UK government announced that the BS 476 series of standards is to be withdrawn and set out a timeline for this.

Test providers

Fire resistance testing was undertaken at BRE Global and Warrington Fire with differing sized furnaces and loading mechanisms. The size and loading arrangements of the test specimens was therefore dictated by the size of the furnace in each test facility. This provided variety and valuable learning from recognised independent test authorities, all of whom were UKAS accredited.

Services

Although not required under the test standard, a push fit plastic double socket was fitted in the bottom corner of external wall assemblies tested by STA.

Research data

Additional research orientated thermocouples were included within all tests undertaken. This provided valuable research data to help inform the performance of tested systems under fire.

Test loading

Each system tested by the STA was loaded to the maximum stud capacity of 100% in accordance with EN load reduction factor design criteria. Part 12.1 provides more information.

Resilience

The fire safety of buildings requires more than passing tests and compliance with minimum code levels. This Pattern Book of solutions takes into consideration working practises, specifications and detailing. The solutions include higher levels of resilience and improved specifications, sensitive to critical areas of fire safety compliance. This provides resilience to accommodate, real world practises during design, specification, procurement and construction.

Test reports

Test reports were completed for all tests undertaken. These were collated and checked for accuracy against the design and as-built test specimens. Test reports are governed under STA intellectual property and copyright laws. These are not for release to 3rd parties. As a requirement of developing the Pattern Book, test reports were made available for BRE Global peer review, as well as verifiers and regulators. The Pattern Book provides deemed to satisfy style solutions, accepted by verifiers and regulators, without the need to provide test reports.

All STA test reports for the wall systems shown in Parts 3 to 7 of the Pattern Book were assessed by BRE Global; reviewing materials and specifications adopted by the STA. All test reports, findings and thermocouple data were analysed.

Generic material and supplier classifications

Following the STA testing, Milner Associates undertook an assessment of generic material classifications of Type A plasterboard, PIR and mineral insulations, used in the STA testing programme, from a range of suppliers in the UK.

This assessment was specific to the wall testing undertaken by the STA. This cannot be interpolated for use in bespoke external walls, roof and floor applications tested by others.

The STA research and testing programme focused on the use of 15mm Type A boards for wall make ups, in consideration of the resilience required, loadings applied, services incorporated and the more onerous EN fire resistance test standard being adopted.

The assessment work reviewed the plasterboard material variability research undertaken, the test outcomes, the thermocouple test data under fire load test conditions and the resilience built into the test pass thresholds.

This supported the agreement to specify generic classifications of materials noted below from a variety of mainstream UK suppliers:

1. Type A and F Plasterboard - manufactured to BS EN 520:2004, from British Gypsum, Siniat or Knauf.
2. Polyisocyanurate Insulation (PIR) - manufactured to BS EN 13165
3. Glass Wool Insulation - manufactured to BS EN 13162:2012 (+A1:2015) and EN 13172:2012
4. Drylining Screws - manufactured to BS EN 14566
5. Stone Wool Insulation - manufactured to BS EN 13162:2012

2.6 Third-party EN fire resistance testing

The STA has been working in partnership with other timber building system associations and supply chains, to gather test information for inclusion within the STA Pattern Book. This collaborative approach will provides a greater range of EN tested systems available to members, clients and specifiers as part of a whole building approach to design.

These systems have been individually or collectively tested to EN 1365-1 or EN 1365-2 fire resistance tests for load bearing elements (wall, floor and roof applications) by the relevant governing trade association, organisation or supplier.

The floor systems included in this version of the pattern book were not tested as part of the STA research programme, but have been tested by the relevant joist manufacturers. A significant number of fire test reports have been analysed and third-party peer reviewed to produce the six floor systems presented in this version of the Pattern Book.

2.7 Pattern Book - tested systems

Each system has been drafted into a Pattern Book approach providing simple to understand, key information based on test evidence. REI classifications are used in fire resistance testing to represent failure modes. The failure classifications are R = loadbearing capacity, E = integrity and I = insulation.

STA tests reports of the Pattern Book have been checked for accuracy by the STA working party. The full test reports are controlled documents, governed under intellectual property and copyright by the STA. All research and test information are governed by the STA Technical Committee and Executive Board.



3. Generic wall systems

3.1.1 EW30-GW-01 REI30 external wall

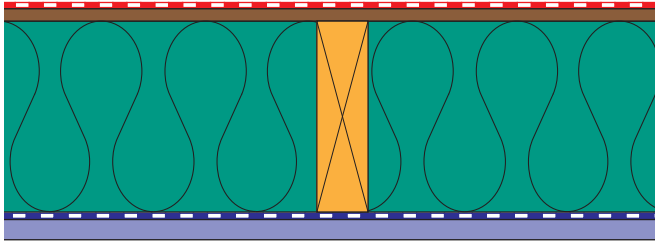

VERIFICATION DETAILS

Based on testing to	BS EN 1365-1:2012 (loaded)
Load applied	100% of in-service design capacity
Limitation	Wall panels up to 2.7m high
3rd party peer review	Milner Associates in collaboration with BRE Global
Fire exposure	Plasterboard face

	MATERIAL	FIXING
INNER FACE¹	1 x minimum 15mm Type A or F plasterboard. All joints mesh taped and filled NOTE: Horizontal board joints require minimum 38mm x 63mm C16 timber noggings at board joint	In accordance with BG, Knauf or Siniat fixings requirements Typically, 3.5mm x 38mm self-tapping drywall screws @ maximum 300mm CTRS
	Vapour control layer (VCL) adjacent to the insulation layer	VCL stapled to studs and top/bottom rails
CLOSED PANEL OPTION¹	Minimum 9mm wood-based board fixed to the wall studs and rails (OSB/3, plywood) NOTE: The addition of a wood-based board behind the plasterboard has no detrimental impact on this fire resistance performance	In accordance with structural engineer's fixing requirements Typically, 2.8mm x 50mm smooth shank nails @ 150mm CTRS (perimeter) and 300mm CTRS (intermediate studs)
INSULATION¹	Full fill glass or stone wool with thermal conductivity of 0.040 W/mK or lower value for improved thermal performance	Friction fitted without fixings
STUDS¹	Minimum 38mm x 140mm C16 CLS timber @ 600mm CTRS NOTE: Studs at closer centres and multiple stud clusters, has no detrimental impact on fire resistance performance	In accordance with structural engineer's fixing requirements Typically, 3.1mm x 88mm twist shank nails, 2 per stud
NOGGINGS¹	Timber ancillary or structural noggings, as required NOTE: The addition of noggings has no detrimental impact on the fire resistance performance	Typically, 3.1mm x 88mm twist shank nails, 2 per stud to nogging

3.1.1 EW30-GW-01 REI30 external wall cont.../

	MATERIAL	FIXING
EXTERNAL FACE¹	Minimum 9mm sheathing (OSB/3, plywood or euro-class A1/A2 boarding) breather paper and marker tapes NOTE: Differing breather membranes have no detrimental impact on the fire resistance performance	In accordance with structural engineer's fixing requirements Typically, 2.8mm x 50mm smooth shank nails @ 150mm CTRS (perimeter) and 300mm CTRS (intermediate studs) Breather membrane stapled to studs and top/bottom rails
SERVICE PENETRATIONS¹	In accordance with national guidance ² or fire stopped with an EI30 fire tested product to BS EN 1366 for the application or verified by manufacturer's test data for the application	In accordance with the requirements of the fire stopping provision

NOTES:

¹ The designer shall ensure that the wall assembly complies with the Building Regulations, any other relevant statutory guidance and project specification where more onerous for example: structural, acoustic, thermal etc.

² National Statutory Guidance:

- England and Wales: Approved Documents
- Scotland: Technical Handbooks
- Northern Ireland: Technical Booklets

3.1.2 EW30-GW-02 REI30 external wall

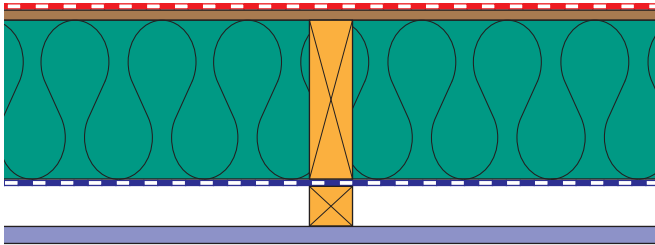

VERIFICATION DETAILS

Based on testing to	BS EN 1365-1 (loaded)
Load applied	100% of in-service design capacity
Limitation	Wall panels up to 2.7m high
3rd party peer review	Milner Associates in collaboration with BRE Global
Fire exposure	Plasterboard face

	MATERIAL	FIXING
INNER FACE¹	1 x minimum 15mm Type A or F plasterboard. All joints mesh taped and filled NOTE: Horizontal board joints require minimum 38mm wide x 25-38mm deep timber battens at board joint	In accordance with BG, Knauf or Siniat fixings requirements Typically, 3.5mm x 38mm self-tapping drywall screws @ maximum 300mm CTRS
SERVICE ZONE¹	Minimum 38mm wide x minimum 25mm up to maximum 38mm deep timber battens aligned and fixed to studs to provide the necessary plasterboard fixing spacing Vapour control layer (VCL) adjacent to the insulation layer	Typically, 3.1mm x 90mm smooth shank nails or 5.0mm x 90mm self-tapping screws @ maximum 300mm CTRS VCL stapled to studs and top/bottom rails
CLOSED PANEL OPTION¹	Minimum 9mm wood-based board with VCL fixed into the wall studs and rails (OSB/3, plywood) NOTE: The addition of a wood-based board behind the service zone has no detrimental impact on the fire resistance performance	In accordance with structural engineer's fixing requirements Typically, 2.8mm x 50mm smooth shank nails @ 150mm CTRS (perimeter) and 300mm CTRS (intermediate studs)
INSULATION¹	Full fill glass or stone wool with thermal conductivity of 0.040 W/mK or lower value for improved thermal performance	Friction fitted without fixings
STUDS¹	Minimum 38mm x 140mm C16 timber @ 600mm CTRS NOTE: Studs at closer centres and multiple stud clusters, has no detrimental impact on fire resistance performance	In accordance with structural engineer's fixing requirements Typically, 3.1mm x 90mm twist shank nails, 2 per stud

3.1.2 EW30-GW-02 REI30 external wall cont.../

	MATERIAL	FIXING
NOGGINGS¹	Timber ancillary or structural noggings, as required NOTE: <i>The addition of noggings has no detrimental impact on the fire resistance performance</i>	Typically, 3.1mm x 90mm twist shank nails, 2 per stud to nogging
EXTERNAL FACE¹	Minimum 9mm sheathing (OSB/3, plywood or euro-class A1/A2 boarding) breather membrane and marker tapes NOTE: <i>Differing breather membranes have no detrimental impact on the fire resistance performance</i>	In accordance with structural engineer's fixing requirements Typically, 2.8mm x 50mm smooth shank nails @ 150mm CTRS (perimeter) and 300mm CTRS (intermediate studs) Breather membrane stapled to studs and top/bottom rails
SERVICE PENETRATIONS¹	In accordance with national guidance ² or fire stopped with an EI30 fire tested product to BS EN 1366 for the application or verified by manufacturer's test data for the application	In accordance with the requirements of the fire stopping provision

NOTES:

¹ The designer shall ensure that the wall assembly complies with the Building Regulations, any other relevant statutory guidance and project specification where more onerous for example: structural, acoustic, thermal etc.

² National Statutory Guidance:

- England and Wales: Approved Documents
- Scotland: Technical Handbooks
- Northern Ireland: Technical Booklets

3.1.3 EW30-GW-03 REI30 external wall

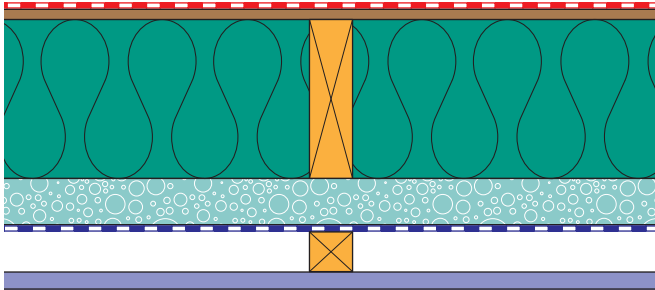

VERIFICATION DETAILS

Based on testing to	BS EN 1365-1 (loaded)
Load applied	100% of in-service design capacity
Limitation	Wall panels up to 2.7m high
3rd party peer review	Milner Associates in collaboration with BRE Global
Fire exposure	Plasterboard face

	MATERIAL	FIXING
INNER FACE¹	1 x minimum 15mm Type A or F plasterboard. All joints mesh taped and filled NOTE: Horizontal board joints require minimum 38mm wide x 25-38mm deep timber battens at board joint	In accordance with BG, Knauf or Siniat fixings requirements Typically, 3.5mm x 38mm self-tapping drywall screws @ maximum 300mm CTRS
SERVICE ZONE¹	Minimum 38mm wide x minimum 25mm up to maximum 38mm deep timber battens aligned and fixed to studs to provide the necessary plasterboard fixing spacing. Batten depth limited by fixings Vapour control layer (VCL) adjacent to the insulation layer	Typically, 3.1mm x 90mm smooth shank nails or 5.0mm x 90mm self-tapping screws @ maximum 300mm CTRS VCL stapled to studs and top/bottom rails
OVER-BOARD INSULATION¹	Minimum 25mm PIR insulation with thermal conductivity of 0.022 W/mK or lower value for improved thermal performance, sandwiched between battens and studs	For up to 25mm PIR insulation typically, 3.1mm x 90mm smooth shank nails or 5.0mm x 90mm self-tapping screws @ maximum 300mm CTRS For greater thicknesses the fixings are to be justified by the project structural engineer.
CLOSED PANEL OPTION¹	Minimum 9mm wood-based board fixed into the wall studs and rails (OSB/3, plywood) NOTE: The addition of a wood-based board behind the over-board insulation has no detrimental impact on the fire resistance performance	In accordance with structural engineer's fixing requirements Typically, 2.8mm x 50mm smooth shank nails @ 150mm CTRS (perimeter) and 300mm CTRS (intermediate studs)
INSULATION BETWEEN STUDS¹	Full fill glass or stone wool with thermal conductivity of 0.040 W/mK or lower value for improved thermal resistance performance	Friction fitted without fixings
STUDS¹	Minimum 38mm x 140mm C16 timber @ 600mm CTRS NOTE: Studs at closer centres and multiple stud clusters, has no detrimental impact on fire resistance performance	In accordance with structural engineer's fixing requirements Typically, 3.1mm x 90mm twist shank nails, 2 per stud

3.1.3 EW30-GW-03 REI30 external wall cont.../

	MATERIAL	FIXING
NOGGINGS¹	Timber ancillary or structural noggings, as required NOTE: The addition of noggings has no detrimental impact on the fire resistance performance	Typically, 3.1mm x 90mm twist shank nails, 2 per stud to nogging
EXTERNAL FACE¹	Minimum 9mm sheathing (OSB/3, plywood or euro-class A1/A2 boarding) breather membrane and marker tapes NOTE: Differing breather membranes have no detrimental impact on the fire resistance performance	In accordance with structural engineer's fixing requirements Typically, 2.8mm x 50mm smooth shank nails @ 150mm CTRS (perimeter) and 300mm CTRS (intermediate studs) Breather membrane stapled to studs and top/bottom rails
SERVICE PENETRATIONS¹	In accordance with national guidance ² or fire stopped with an EI30 fire tested product to BS EN 1366 for the application or verified by manufacturer's test data for the application	In accordance with the requirements of the fire stopping provision

NOTES:

¹ The designer shall ensure that the wall assembly complies with the Building Regulations, any other relevant statutory guidance and project specification where more onerous for example: structural, acoustic, thermal etc.

² National Statutory Guidance:

- England and Wales: Approved Documents
- Scotland: Technical Handbooks
- Northern Ireland: Technical Booklets

3.2.1 EW30-PIR-01 REI30 external wall

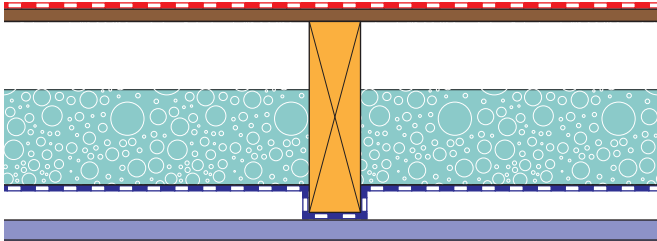

VERIFICATION DETAILS

Based on testing to	BS EN 1365-1:2012 (loaded)
Load applied	100% of in-service design capacity
Limitation	Wall panels up to 2.7m high
3rd party peer review	Milner Associates in collaboration with BRE Global
Fire exposure	Plasterboard face

	MATERIAL	FIXING
INNER FACE ¹	1 x minimum 15mm Type A or F plasterboard. All joints mesh taped and filled NOTE: Horizontal board joints require minimum 38mm x 63mm C16 timber noggings at board joint	In accordance with BG, Knauf or Siniat fixings requirements Typically, 3.5mm x 38mm self-tapping drywall screws @ maximum 300mm CTRS
	Vapour control layer (VCL) adjacent to the insulation layer (position to be agreed with building control)	VCL stapled to studs and top/bottom rails
CLOSED PANEL OPTION ¹	Minimum 9mm wood-based board fixed to the wall studs and rails (OSB/3, plywood) NOTE: The addition of a wood-based board behind the plasterboard has no detrimental impact on the fire resistance performance	In accordance with structural engineer's fixing requirements Typically, 2.8mm x 50mm smooth shank nails @ 150mm CTRS (perimeter) and 300mm CTRS (intermediate studs)
INSULATION ¹	Minimum 70mm PIR insulation with thermal conductivity of 0.022 W/mK or lower value for improved thermal performance NOTE: PIR insulation to be located such that there is an air gap of 0 to 35mm	Tightly site fitted between studs, in accordance with manufacturer's recommendations or factory fitted using metal clips to timber frame manufacturer's details NOTE: Gaps between boards or board to stud greater than 2mm must be filled with intumescent sealant
STUDS ¹	Minimum 38mm x 140mm C16 CLS timber @ 600mm CTRS NOTE: Studs at closer centres and multiple stud clusters, has no detrimental impact on fire resistance performance	In accordance with structural engineer's fixing requirements Typically, 3.1mm x 88mm twist shank nails, 2 per stud
NOGGINGS ¹	Timber ancillary or structural noggings, as required NOTE: The addition of noggings has no detrimental impact on the fire resistance performance	Typically, 3.1mm x 88mm twist shank nails, 2 per stud to nogging

3.2.1 EW30-PIR-01 REI30 external wall cont.../

	MATERIAL	FIXING
EXTERNAL FACE¹	<p>Minimum 9mm sheathing (OSB/3, plywood or euro-class A1/A2 boarding) breather paper and marker tapes</p> <p>NOTE: Differing breather membranes have no detrimental impact on the fire resistance performance</p>	<p>In accordance with structural engineer's fixing requirements</p> <p>Typically, 2.8mm x 50mm smooth shank nails @ 150mm CTRS (perimeter) and 300mm CTRS (intermediate studs)</p> <p>Breather membrane stapled to studs and top/bottom rails</p>
SERVICE PENETRATIONS¹	<p>In accordance with national guidance² or fire stopped with an EI30 fire tested product to BS EN 1366 for the application or verified by manufacturer's test data for the application</p>	<p>In accordance with the requirements of the fire stopping provision</p>

NOTES:

¹ The designer shall ensure that the wall assembly complies with the Building Regulations, any other relevant statutory guidance and project specification where more onerous for example: structural, acoustic, thermal etc.

² National Statutory Guidance:

- England and Wales: Approved Documents
- Scotland: Technical Handbooks
- Northern Ireland: Technical Booklets

3.2.2 EW30-PIR-02 REI30 external wall

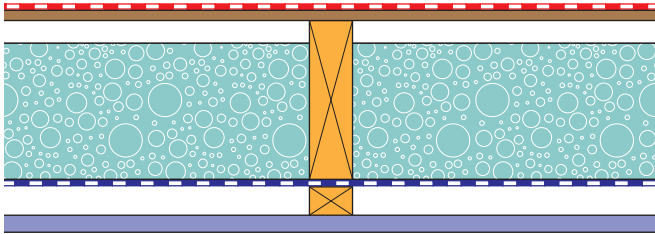

VERIFICATION DETAILS

Based on testing to	BS EN 1365-1 (loaded)
Load applied	100% of in-service design capacity
Limitation	Wall panels up to 2.7m high
3rd party peer review	Milner Associates in collaboration with BRE Global
Fire exposure	Plasterboard face

	MATERIAL	FIXING
INNER FACE¹	1 x minimum 15mm Type A or F plasterboard. All joints mesh taped and filled NOTE: Horizontal board joints require minimum 38mm wide x 25-38mm deep timber battens at board joint	In accordance with BG, Knauf or Siniat fixings requirements Typically, 3.5mm x 38mm self-tapping drywall screws @ maximum 300mm CTRS
SERVICE ZONE¹	Minimum 38mm wide x minimum 25mm up to maximum 38mm deep timber battens aligned and fixed to studs to provide the necessary plasterboard fixing spacing. Batten depth limited by fixings Vapour control layer (VCL) adjacent to the insulation layer (position to be agreed with building control)	Typically, 3.1mm x 90mm smooth shank nails or 5.0mm x 90mm self-tapping screws @ maximum 300mm CTRS VCL stapled to studs and top/bottom rails
CLOSED PANEL OPTION¹	Minimum 9mm wood-based board fixed into the wall studs and rails (OSB/3, plywood) NOTE: The addition of a wood-based board behind the service zone has no detrimental impact on the fire resistance performance	In accordance with structural engineer's fixing requirements Typically, 2.8mm x 50mm smooth shank nails @ 150mm CTRS (perimeter) and 300mm CTRS (intermediate studs)
INSULATION¹	Minimum 120mm PIR insulation with thermal conductivity of 0.022 W/mK or lower value for improved thermal performance NOTE: PIR insulation can be fitted anywhere between the timber with 0 to 20mm maximum air gap behind the VCL or outer face	Tightly site fitted between studs, in accordance with manufacturer's recommendations or factory fitted using metal clips to timber frame manufacturer's details NOTE: Gaps greater than 2mm must be filled with intumescent sealant
STUDS¹	Minimum 38mm x 140mm C16 timber @ 600mm CTRS NOTE: Studs at closer centres and multiple stud clusters, has no detrimental impact on fire resistance performance	In accordance with structural engineer's fixing requirements Typically, 3.1mm x 90mm twist shank nails, 2 per stud
NOGGINGS¹	Timber ancillary or structural noggings, as required NOTE: The addition of noggings has no detrimental impact on the fire resistance performance	Typically, 3.1mm x 90mm twist shank nails, 2 per stud to nogging

3.2.2 EW30-PIR-02 REI30 external wall cont.../

	MATERIAL	FIXING
EXTERNAL FACE¹	<p>Minimum 9mm sheathing (OSB/3, plywood or euro-class A1/A2 boarding) breather membrane and marker tapes</p> <p>NOTE: Differing breather membranes have no detrimental impact on the fire resistance performance</p>	<p>In accordance with structural engineer's fixing requirements</p> <p>Typically, 2.8mm x 50mm smooth shank nails @ 150mm CTRS (perimeter) and 300mm CTRS (intermediate studs)</p> <p>Breather membrane stapled to studs and top/bottom rails</p>
SERVICE PENETRATIONS¹	<p>In accordance with national guidance² or fire stopped with an EI30 fire tested product to BS EN 1366 for the application or verified by manufacturer's test data for the application</p>	<p>In accordance with the requirements of the fire stopping provision</p>

NOTES:

¹ The designer shall ensure that the wall assembly complies with the Building Regulations, any other relevant statutory guidance and project specification where more onerous for example: structural, acoustic, thermal etc.

² National Statutory Guidance:

- England and Wales: Approved Documents
- Scotland: Technical Handbooks
- Northern Ireland: Technical Booklets

3.2.3 EW30-PIR-03 REI30 external wall, service zone and PIR over PIR insulation

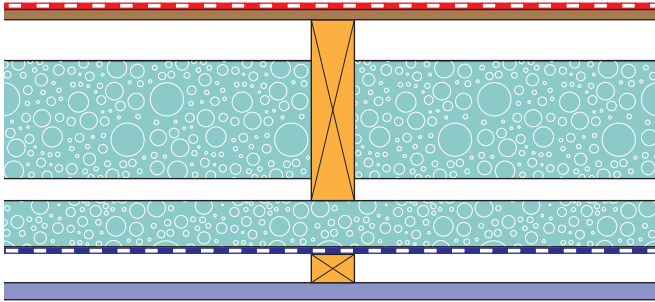

VERIFICATION DETAILS

Based on testing to	BS EN 1365-1 (loaded)
Load applied	100% of in-service design capacity
Limitation	Wall panels up to 2.7m high
3rd party peer review	Milner Associates in collaboration with BRE Global
Fire exposure	Plasterboard face

	MATERIAL	FIXING
INNER FACE¹	1 x minimum 15mm Type A or F plasterboard All joints mesh taped and filled NOTE: Horizontal board joints require minimum 38mm wide x 25-38mm deep timber battens at board joint	In accordance with BG, Knauf or Siniat fixings requirements Typically, 3.5mm x 60mm self-tapping drywall screws @ maximum 300mm CTRS
SERVICE ZONE¹	Minimum 38mm wide x minimum 25mm up to maximum 38mm deep timber battens aligned and fixed to studs to provide the necessary plasterboard fixing spacing. Batten depth limited by fixings Vapour control layer (VCL) adjacent to the insulation layer	In accordance with structural engineer's fixing requirements Typically, 3.1mm x 90mm smooth shank nails or 5.0mm x 90mm self-tapping screws @ maximum 300mm CTRS VCL stapled to studs and top/bottom rails
OVER-BOARD INSULATION¹	Minimum 25mm PIR Insulation (0.022 W/mK) sandwiched between battens and studs	In accordance with structural engineer's fixing requirements Typically 3.1mm x 90mm smooth shank nails or 5.0mm x 90mm self-tapping screws @ maximum 300mm CTRS for PIR insulation up to 25mm thick For greater thicknesses of PIR, the fixings are to be justified by the project structural engineer
CLOSED PANEL OPTION¹	Minimum 9mm wood-based board with VCL fixed into the wall studs and rails (OSB/3, plywood) NOTE: The addition of a wood-based board behind the plasterboard has no detrimental impact on the fire resistance performance	In accordance with structural engineer's fixing requirements Typically, 2.8mm x 50mm smooth shank nails @ 150mm CTRS (perimeter) and 300mm CTRS (intermediate studs)
INSULATION BETWEEN STUDS¹	Minimum 120mm PIR insulation with thermal conductivity of 0.022 W/mK or lower value for improved thermal performance NOTE: PIR insulation can be fitted anywhere between the timber studs with 0 to 20mm maximum air gap behind the inner or outer face	Tightly site fitted between studs, in accordance with manufacturer's recommendations or factory fitted using metal clips to timber frame manufacturer's details NOTE: Gaps greater than 2mm must be filled with intumescent sealant to full depth of gap

3.2.3 EW30-PIR-03 REI30 external wall, service zone and PIR over PIR insulation cont.../

	MATERIAL	FIXING
STUDS¹	<p>Minimum 38mm x 140mm C16 timber @ 600mm CTRS</p> <p>NOTE: Studs at closer centres and multiple stud clusters have no detrimental impact on fire resistance performance</p>	<p>In accordance with structural engineer's fixing requirements</p> <p>Typically, 3.1mm x 90mm twist shank nails, 2 per stud</p>
NOGGINS¹	<p>Timber ancillary or structural noggings, as required</p> <p>NOTE: The addition of noggings has no detrimental impact on the fire resistance performance</p>	<p>Typically, 3.1mm x 90mm twist shank nails, 2 per stud to nogging</p>
EXTERNAL FACE¹	<p>Minimum 9mm sheathing (OSB/3, plywood or euro-class A1/A2 boarding)</p> <p>Breather membrane and marker tapes</p> <p>NOTE: Differing breather membranes have no detrimental impact on the fire resistance performance</p>	<p>In accordance with structural engineer's fixing requirements</p> <p>Typically, 2.8mm x 50mm smooth shank nails @ 150mm CTRS (perimeter) and 300mm CTRS (intermediate studs)</p> <p>Breather membrane stapled to studs and top/bottom rails</p>
SERVICE PENETRATIONS¹	<p>In accordance with national guidance² or fire stopped with an EI30 fire tested product to BS EN 1366 for the application or verified by manufacturer's test data for the application</p>	<p>In accordance with the requirements of the fire stopping provision</p>

NOTES:

¹ The designer shall ensure that the wall assembly complies with the Building Regulations, any other relevant statutory guidance and project specification where more onerous for example: structural, acoustic, thermal etc.

² National Statutory Guidance:

- England and Wales: Approved Documents
- Scotland: Technical Handbooks
- Northern Ireland: Technical Booklets

4. Generic external wall systems (REI60)

4.1.1 EW60-GW-01 REI60 external wall

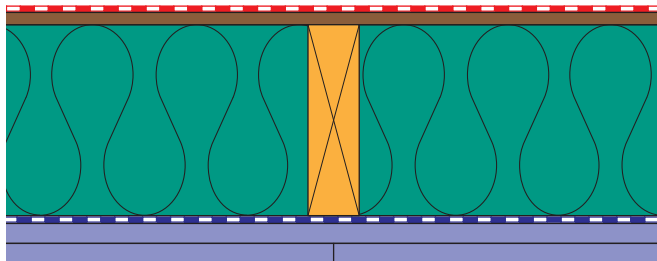

VERIFICATION DETAILS

Based on testing to	BS EN 1365-1:2012 (loaded)
Load applied	100% of in-service design capacity
Limitation	Wall panels up to 2.7m high
3rd party peer review	Milner Associates in collaboration with BRE Global
Fire exposure	Plasterboard face

	MATERIAL	FIXING
INNER FACE ¹	First (outer) layer - 1 x minimum 15mm Type A or F plasterboard. All joints mesh taped and filled NOTE: Plasterboard to have staggered horizontal and vertical joints	In accordance with BG, Knauf or Siniat fixings requirements Typically, 3.5mm x 60mm self-tapping drywall screws @ maximum 300mm CTRS
	Second (inner) layer - 1 x minimum 15mm Type A or F plasterboard. The board joints do not need to be taped and filled NOTE: Horizontal board joints require minimum 38mm x 63mm C16 timber noggings at board joint	In accordance with BG, Knauf or Siniat fixings requirements Typically, 3.5mm x 38mm self-tapping drywall screws @ maximum 300mm CTRS
	Vapour control layer (VCL) adjacent to the insulation layer	VCL stapled to studs and top/bottom rails
CLOSED PANEL OPTION ¹	Minimum 9mm wood-based board fixed to the wall studs and rails (OSB/3, plywood) NOTE: The addition of a wood-based board behind the plasterboard has no detrimental impact on the fire resistance performance	In accordance with structural engineer's fixing requirements Typically, 2.8mm x 50mm smooth shank nails @ 150mm CTRS (perimeter) and 300mm CTRS (intermediate studs)
INSULATION ¹	Full fill glass or stone wool with thermal conductivity of 0.040 W/mK or lower value for improved thermal performance	Friction fitted without fixings
STUDS ¹	Minimum 38mm x 140mm C16 CLS timber @ 600mm CTRS NOTE: Studs at closer centres and multiple stud clusters, has no detrimental impact on fire resistance performance	In accordance with structural engineer's fixing requirements Typically, 3.1mm x 88mm twist shank nails, 2 per stud
NOGGINGS ¹	Timber ancillary or structural noggings, as required NOTE: The addition of noggings has no detrimental impact on the fire resistance performance	Typically, 3.1mm x 88mm twist shank nails, 2 per stud to noggings

4.1.1 EW60-GW-01 REI60 external wall cont.../

	MATERIAL	FIXING
EXTERNAL FACE¹	Minimum 9mm sheathing (OSB/3, plywood or euro-class A1/A2 boarding) breather paper and marker tapes NOTE: Differing breather membranes have no detrimental impact on the fire resistance performance	In accordance with structural engineer's fixing requirements Typically, 2.8mm x 50mm smooth shank nails @ 150mm CTRS (perimeter) and 300mm CTRS (intermediate studs) Breather membrane stapled to studs and top/bottom rails
SERVICE PENETRATIONS¹	In accordance with national guidance ² or fire stopped with an EI60 fire tested product to BS EN 1366 for the application or verified by manufacturer's test data for the application	In accordance with the requirements of the fire stopping provision

NOTES:

¹ The designer shall ensure that the wall assembly complies with the Building Regulations, any other relevant statutory guidance and project specification where more onerous for example: structural, acoustic, thermal etc.

² National Statutory Guidance:

- England and Wales: Approved Documents
- Scotland: Technical Handbooks
- Northern Ireland: Technical Booklets

4.1.2 EW60-GW-02 REI60 external wall

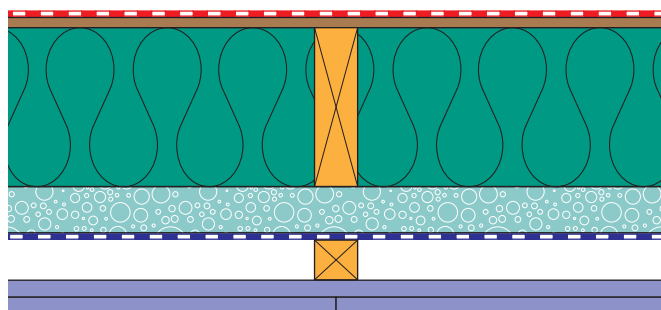

VERIFICATION DETAILS

Based on testing to	BS EN 1365-1 (loaded)
Load applied	100% of in-service design capacity
Limitation	Wall panels up to 2.7m high
3rd party peer review	Milner Associates in collaboration with BRE Global
Fire exposure	Plasterboard face

	MATERIAL	FIXING
INNER FACE¹	First (outer) layer - 1 x minimum 15mm Type A or F plasterboard. All joints mesh taped and filled NOTE: Plasterboard to have staggered horizontal and vertical joints	In accordance with BG, Knauf or Siniat fixings requirements Typically, 3.5mm x 60mm self-tapping drywall screws @ maximum 300mm CTRS
	Second (inner) layer - 1 x minimum 15mm Type A or F plasterboard. The board joints do not need to be taped and filled NOTE: Horizontal board joints require minimum 38mm wide x 25-38mm deep timber battens at board joint	In accordance with BG, Knauf or Siniat fixings requirements Typically, 3.5mm x 38mm self-tapping drywall screws @ maximum 300mm CTRS
SERVICE ZONE¹	Minimum 38mm wide x minimum 25mm up to maximum 38mm deep timber battens aligned and fixed to studs to provide the necessary plasterboard fixing spacing. Batten depth limited by fixings Vapour control layer (VCL) adjacent to the insulation layer	Typically, 3.1mm x 90mm smooth shank nails or 5.0mm x 90mm self-tapping screws @ maximum 300mm CTRS VCL stapled to studs and top/bottom rails
OVER-BOARD INSULATION¹	25mm to 45mm PIR insulation with thermal conductivity of 0.022 W/mK or lower value for improved thermal performance, sandwiched between battens and studs	For up to 25mm PIR insulation typically, 3.1mm x 90mm smooth shank nails or 5.0mm x 90mm self-tapping screws @ maximum 300mm CTRS. For greater thicknesses the fixings are to be justified by the project structural engineer
CLOSED PANEL OPTION¹	Minimum 9mm wood-based board fixed into the wall studs and rails (OSB/3, plywood) NOTE: The addition of a wood-based board behind the over-board insulation has no detrimental impact on the fire resistance performance	In accordance with structural engineer's fixing requirements Typically, 2.8mm x 50mm smooth shank nails @ 150mm CTRS (perimeter) and 300mm CTRS (intermediate studs)
INSULATION BETWEEN STUDS¹	Full fill glass or stone wool with thermal conductivity of 0.040 W/mK or lower value for improved thermal performance	Friction fitted without fixings
STUDS¹	Minimum 38mm x 140mm C16 timber @ 600mm CTRS NOTE: Studs at closer centres and multiple stud clusters, has no detrimental impact on fire resistance performance	In accordance with structural engineer's fixing requirements Typically, 3.1mm x 90mm twist shank nails, 2 per stud

4.1.2 EW60-GW-02 REI60 external wall cont.../

	MATERIAL	FIXING
NOGGINGS¹	Timber ancillary or structural noggings, as required NOTE: The addition of noggings has no detrimental impact on the fire resistance performance	Typically, 3.1mm x 90mm twist shank nails, 2 per stud to nogging
EXTERNAL FACE¹	Minimum 9mm sheathing (OSB/3, plywood or euro-class A1/A2 boarding) Breather membrane and marker tapes NOTE: Differing breather membranes have no detrimental impact on the fire resistance performance	In accordance with structural engineer's fixing requirements Typically, 2.8mm x 50mm smooth shank nails @ 150mm CTRS (perimeter) and 300mm CTRS (intermediate studs) Breather membrane stapled to studs and top/bottom rails
SERVICE PENETRATIONS¹	In accordance with national guidance ² or fire stopped with an EI60 fire tested product to BS EN 1366 for the application or verified by manufacturer's test data for the application	In accordance with the requirements of the fire stopping provision

NOTES:

¹ The designer shall ensure that the wall assembly complies with the Building Regulations, any other relevant statutory guidance and project specification where more onerous for example: structural, acoustic, thermal etc.

² National Statutory Guidance:

- England and Wales: Approved Documents
- Scotland: Technical Handbooks
- Northern Ireland: Technical Booklets

4.1.3 EW60-GW-03 REI60 external wall, service zone and glass wool insulation

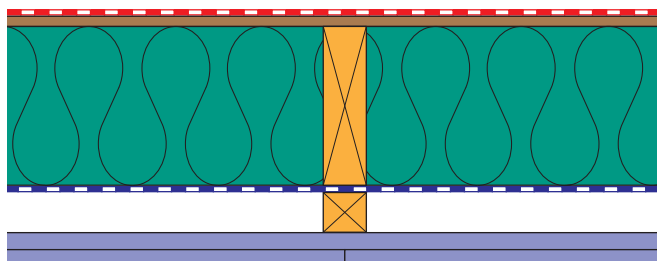

VERIFICATION DETAILS

Based on testing to	BS EN 1365-1 (loaded)
Load applied	100% of in-service design capacity
Limitation	Wall panels up to 2.7m high
3rd party peer review	Milner Associates in collaboration with BRE Global
Fire exposure	Plasterboard face

	MATERIAL	FIXING
INNER FACE¹	First (outer) layer - 1 x minimum 15mm Type A or F plasterboard. All joints mesh taped and filled NOTE: Plasterboard to have staggered horizontal and vertical joints	In accordance with BG, Knauf or Siniat fixings requirements Typically, 3.5mm x 60mm self-tapping drywall screws @ maximum 300mm CTRS
	Second (inner) layer - 1 x minimum 15mm Type A or F plasterboard. The board joints do not need to be taped and filled NOTE: Horizontal board joints require minimum 38mm wide x 25-38mm deep timber battens at board joint	In accordance with BG, Knauf or Siniat fixings requirements Typically, 3.5mm x 38mm self-tapping drywall screws @ maximum 300mm CTRS
SERVICE ZONE¹	Minimum 38mm wide x minimum 25mm up to maximum 38mm deep timber battens aligned and fixed to studs to provide the necessary plasterboard fixing spacing. Batten depth limited by fixings Vapour control layer (VCL) adjacent to the insulation layer	Typically, 3.1mm x 90mm smooth shank nails or 5.0mm x 90mm self-tapping screws @ maximum 300mm CTRS VCL stapled to studs and top/bottom rails
CLOSED PANEL OPTION¹	Minimum 9mm wood-based board fixed into the wall studs and rails (OSB/3, plywood) NOTE: The addition of a wood-based board behind the over-board insulation has no detrimental impact on the fire resistance performance	In accordance with structural engineer's fixing requirements Typically, 2.8mm x 50mm smooth shank nails @ 150mm CTRS (perimeter) and 300mm CTRS (intermediate studs)
INSULATION BETWEEN STUDS¹	Full fill glass or stone wool with thermal conductivity of 0.040 W/mK or lower value for improved thermal performance	Friction fitted without fixings
STUDS¹	Minimum 38mm x 140mm C16 timber @ 600mm CTRS NOTE: Studs at closer centres and multiple stud clusters, has no detrimental impact on fire resistance performance	In accordance with structural engineer's fixing requirements Typically, 3.1mm x 90mm twist shank nails, 2 per stud

4.1.3 EW60-GW-03 REI60 external wall, service zone and glass wool insulation cont.../

	MATERIAL	FIXING
NOGGINGS¹	Timber ancillary or structural noggings, as required NOTE: <i>The addition of noggings has no detrimental impact on the fire resistance performance</i>	Typically, 3.1mm x 90mm twist shank nails, 2 per stud to nogging
EXTERNAL FACE¹	Minimum 9mm sheathing (OSB/3, plywood or euro-class A1/A2 boarding) Breather membrane and marker tapes NOTE: <i>Differing breather membranes have no detrimental impact on the fire resistance performance</i>	In accordance with structural engineer's fixing requirements Typically, 2.8mm x 50mm smooth shank nails @ 150mm CTRS (perimeter) and 300mm CTRS (intermediate studs) Breather membrane stapled to studs and top/bottom rails
SERVICE PENETRATIONS¹	In accordance with national guidance ² or fire stopped with an EI60 fire tested product to BS EN 1366 for the application or verified by manufacturer's test data for the application	In accordance with the requirements of the fire stopping provision

NOTES:

¹ The designer shall ensure that the wall assembly complies with the Building Regulations, any other relevant statutory guidance and project specification where more onerous for example: structural, acoustic, thermal etc.

² National Statutory Guidance:

- England and Wales: Approved Documents
- Scotland: Technical Handbooks
- Northern Ireland: Technical Booklets

4.2.1 EW60-PIR-01 REI60 external wall

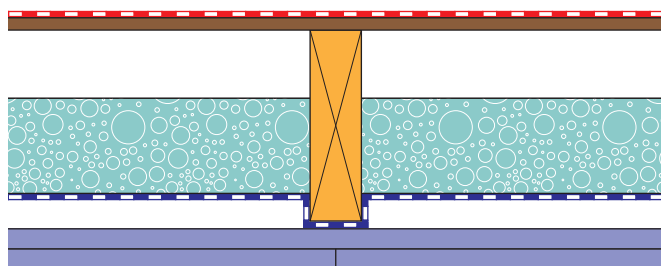

VERIFICATION DETAILS

Based on testing to	BS EN 1365-1:2012 (loaded)
Load applied	100% of in-service design capacity
Limitation	Wall panels up to 2.7m high
3rd party peer review	Milner Associates in collaboration with BRE Global
Fire exposure	Plasterboard face

	MATERIAL	FIXING
INNER FACE¹	First (outer) layer - 1 x minimum 15mm Type A or F plasterboard. All joints mesh taped and filled NOTE: Plasterboard to have staggered horizontal and vertical joints	In accordance with BG, Knauf or Siniat fixings requirements Typically, 3.5mm x 60mm self-tapping drywall screws @ maximum 300mm CTRS
	Second (inner) layer - 1 x minimum 15mm Type A or F plasterboard. The board joints do not need to be taped and filled NOTE: Horizontal board joints require minimum 38mm x 63mm C16 timber noggings at board joint	In accordance with BG, Knauf or Siniat fixings requirements Typically, 3.5mm x 38mm self-tapping drywall screws @ maximum 300mm CTRS
	Vapour control layer (VCL) adjacent to the insulation layer (position to be agreed with building control)	VCL stapled to studs and top/bottom rails
CLOSED PANEL OPTION¹	Minimum 9mm wood-based board fixed to the wall studs and rails (OSB/3, plywood) NOTE: The addition of a wood-based board behind the plasterboard has no detrimental impact on the fire resistance performance	In accordance with structural engineer's fixing requirements Typically, 2.8mm x 50mm smooth shank nails @ 150mm CTRS (perimeter) and 300mm CTRS (intermediate studs)
INSULATION¹	Minimum 70mm PIR insulation of with thermal conductivity 0.022 W/mK or lower value for improved thermal performance NOTE: PIR insulation can be fitted anywhere between the timber with 0 to 35mm maximum air gap behind the VCL or external face	Tightly site fitted between studs, in accordance with manufacturer's recommendations or factory fitted using metal clips to timber frame manufacturer's details NOTE: Gaps greater than 2mm must be filled with intumescent sealant
STUDS¹	Minimum 38mm x 140mm C16 CLS timber @ 600mm CTRS NOTE: Studs at closer centres and multiple stud clusters, has no detrimental impact on fire resistance performance	In accordance with structural engineer's fixing requirements Typically, 3.1mm x 88mm twist shank nails, 2 per stud
NOGGINGS¹	Timber ancillary or structural noggings, as required NOTE: The addition of noggings has no detrimental impact on the fire resistance performance	Typically, 3.1mm x 88mm twist shank nails, 2 per stud to nogging

4.1.3 EW60-GW-03 REI60 external wall, service zone and glass wool insulation cont.../

	MATERIAL	FIXING
EXTERNAL FACE¹	<p>Minimum 9mm sheathing (OSB/3, plywood or euro-class A1/A2 boarding) breather paper and marker tapes</p> <p>NOTE: Differing breather membranes have no detrimental impact on the fire resistance performance</p>	<p>In accordance with structural engineer's fixing requirements</p> <p>Typically, 2.8mm x 50mm smooth shank nails @ 150mm CTRS (perimeter) and 300mm CTRS (intermediate studs)</p> <p>Breather membrane stapled to studs and top/bottom rails</p>
SERVICE PENETRATIONS¹	<p>In accordance with national guidance² or fire stopped with an EI60 fire tested product to BS EN 1366 for the application or verified by manufacturer's test data for the application</p>	<p>In accordance with the requirements of the fire stopping provision</p>

NOTES:

¹ The designer shall ensure that the wall assembly complies with the Building Regulations, any other relevant statutory guidance and project specification where more onerous for example: structural, acoustic, thermal etc.

² National Statutory Guidance:

- England and Wales: Approved Documents
- Scotland: Technical Handbooks
- Northern Ireland: Technical Booklets

4.2.2 EW60-PIR-02 REI60 external wall

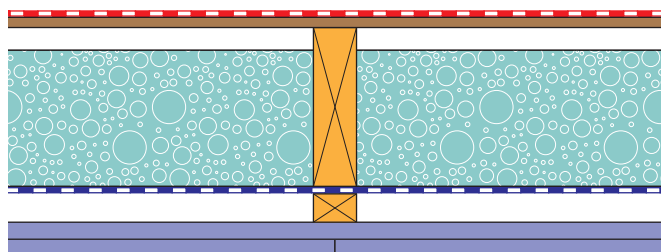

VERIFICATION DETAILS

Based on testing to	BS EN 1365-1 (loaded)
Load applied	100% of in-service design capacity
Limitation	Wall panels up to 2.7m high
3rd party peer review	Milner Associates in collaboration with BRE Global
Fire exposure	Plasterboard face

	MATERIAL	FIXING
INNER FACE¹	First (outer) layer - 1 x minimum 15mm Type A or F plasterboard. All joints mesh taped and filled NOTE: Plasterboard to have staggered horizontal and vertical joints	In accordance with BG, Knauf or Siniat fixings requirements Typically, 3.5mm x 60mm self-tapping drywall screws @ maximum 300mm CTRS
	Second (inner) layer - 1 x minimum 15mm Type A or F plasterboard. The board joints do not need to be taped and filled NOTE: Horizontal board joints require minimum 38mm wide x 25-38mm deep timber battens at board joint	In accordance with BG, Knauf or Siniat fixings requirements Typically, 3.5mm x 38mm self-tapping drywall screws @ maximum 300mm CTRS
SERVICE ZONE¹	Minimum 38mm wide x minimum 25mm up to maximum 38mm deep timber battens aligned and fixed to studs to provide the necessary plasterboard fixing spacing. Batten depth limited by fixings Vapour control layer (VCL) adjacent to the insulation layer (position to be agreed with building control)	Typically, 3.1mm x 90mm smooth shank nails or 5.0mm x 90mm self-tapping screws @ maximum 300mm CTRS VCL stapled to studs and top/bottom rails
CLOSED PANEL OPTION¹	Minimum 9mm wood-based board with VCL fixed into the wall studs and rails (OSB/3, plywood) NOTE: The addition of a wood-based board behind the service zone has no detrimental impact on the fire resistance performance	In accordance with structural engineer's fixing requirements Typically, 2.8mm x 50mm smooth shank nails @ 150mm CTRS (perimeter) and 300mm CTRS (intermediate studs)
INSULATION¹	Minimum 120mm PIR insulation with thermal conductivity of 0.022 W/mK or lower value for improved thermal performance NOTE: PIR insulation can be fitted anywhere between the timber with 0 to 20mm maximum air gap behind the VCL or external face	Tightly site fitted between studs, in accordance with manufacturer's recommendations or factory fitted using metal clips to timber frame manufacturer's details NOTE: Gaps greater than 2mm must be filled with intumescent sealant
STUDS¹	Minimum 38mm x 140mm C16 timber @ 600mm CTRS NOTE: Studs at closer centres and multiple stud clusters, has no detrimental impact on fire resistance performance	In accordance with structural engineer's fixing requirements Typically, 3.1mm x 90mm twist shank nails, 2 per stud

4.2.2 EW60-PIR-02 REI60 external wall cont.../

	MATERIAL	FIXING
NOGGINGS¹	Timber ancillary or structural noggings, as required NOTE: The addition of noggings has no detrimental impact on the fire resistance performance	Typically, 3.1mm x 90mm twist shank nails, 2 per stud to nogging
EXTERNAL FACE¹	Minimum 9mm sheathing (OSB/3, plywood or euro-class A1/A2 boarding) breather membrane and marker tapes NOTE: Differing breather membranes have no detrimental impact on the fire resistance performance	In accordance with structural engineer's fixing requirements Typically, 2.8mm x 50mm smooth shank nails @ 150mm CTRS (perimeter) and 300mm CTRS (intermediate studs) Breather membrane stapled to studs and top/bottom rails
SERVICE PENETRATIONS¹	In accordance with national guidance ² or fire stopped with an EI60 fire tested product to BS EN 1366 for the application or verified by manufacturer's test data for the application	In accordance with the requirements of the fire stopping provision

NOTES:

¹ The designer shall ensure that the wall assembly complies with the Building Regulations, any other relevant statutory guidance and project specification where more onerous for example: structural, acoustic, thermal etc.

² National Statutory Guidance:

- England and Wales: Approved Documents
- Scotland: Technical Handbooks
- Northern Ireland: Technical Booklets

5. Generic internal loadbearing wall systems (REI30)

5.1 IW30-V-01 REI30 internal wall

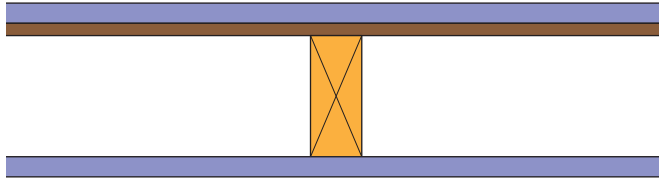

VERIFICATION DETAILS

Based on testing to	BS EN 1365-1:2012 (loaded)
Load applied	100% of in-service design capacity
Limitation	Wall panels up to 2.7m high
3rd party peer review	Milner Associates in collaboration with BRE Global
Fire exposure	Each side separately

	MATERIAL	FIXING
ROOM FACE BOTH SIDES¹	1 x minimum 15mm Type A or F plasterboard. All joints mesh taped and filled NOTE: Horizontal board joints require minimum 38mm x 63mm C16 timber noggings at board joint	In accordance with BG, Knauf or Siniat fixings requirements Typically, 3.5mm x 38mm self-tapping drywall screws @ maximum 300mm CTRS Tightly site fitted between studs, in accordance with manufacturer's recommendations or factory fitted using metal clips to timber frame manufacturer's details
INSULATION¹	Optional - for acoustic/thermal purposes, full or partial fill, glass or stone wool insulation NOTE: The addition of mineral wool insulation has no detrimental impact on the fire resistance performance	Friction fitted without fixings
STUDS¹	Minimum 38mm x 89mm C16 CLS timber @ 600mm CTRS NOTE: The addition of studs at closer centres and multiple stud clusters, has no detrimental impact on fire resistance performance	In accordance with structural engineer's fixing requirements Typically, 3.1mm x 88mm twist shank nails, 2 per stud
UNSHEATHED OPTION¹	1 x row 38mm x 89mm C16 CLS timber mid height noggings, staggered NOTE: The addition of mid-height noggings has no detrimental impact on fire resistance performance	In accordance with structural engineer's fixing requirements Typically, 3.1mm x 88mm twist shank nails, 2 per stud/nogging connection
SHEATHED OPTION¹	Minimum 9mm sheathing (OSB/3, plywood or euro-class A1/A2 boarding) NOTE: Sheathing is an optional requirement for structural purposes NOTE: The addition of sheathing has no detrimental impact on fire resistance	In accordance with structural engineer's fixing requirements Typically, 2.8mm x 50mm smooth shank nails @ 150mm CTRS (perimeter) and 300mm CTRS (intermediate studs)

5. Generic internal loadbearing wall systems (REI30)

5.1 IW30-V-01 REI30 internal wall cont.../

	MATERIAL	FIXING
NOGGINGS¹	Timber ancillary or structural noggings, as required NOTE: <i>The addition of noggings has no detrimental impact on the fire resistance performance</i>	Typically, 3.1mm x 88mm twist shank nails, 2 per stud to nogging
SERVICE PENETRATIONS¹	In accordance with national guidance ² or fire stopped with an EI30 fire tested product to BS EN 1366 for the application or verified by manufacturer's test data for the application	In accordance with the requirements of the fire stopping provision

NOTES:

¹ The designer shall ensure that the wall assembly complies with the Building Regulations, any other relevant statutory guidance and project specification where more onerous for example: structural, acoustic, thermal etc.

² National Statutory Guidance:

- England and Wales: Approved Documents
- Scotland: Technical Handbooks
- Northern Ireland: Technical Booklets

6. Generic internal loadbearing wall systems (REI60)

6.1 IW60-V-01 REI60 internal wall

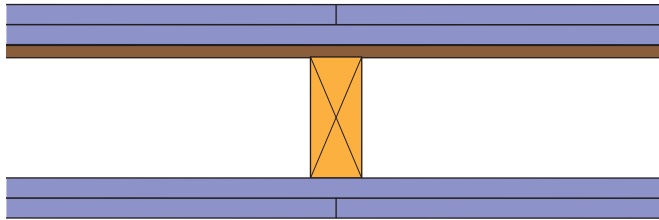

VERIFICATION DETAILS

Based on testing to	BS EN 1365-1:2012 (loaded)
Load applied	100% of in-service design capacity
Limitation	Wall panels up to 2.7m high
3rd party peer review	Milner Associates in collaboration with BRE Global
Fire exposure	Each side separately

	MATERIAL	FIXING
ROOM FACE BOTH SIDES¹	First (outer) layer - 1 x minimum 15mm Type A or F plasterboard. All joints mesh taped and filled NOTE: Plasterboard to have staggered horizontal and vertical joints	In accordance with BG, Knauf or Siniat fixings requirements Typically, 3.5mm x 60mm self-tapping drywall screws @ maximum 300mm CTRS
	Second (inner) layer - 1 x minimum 15mm Type A or F plasterboard. The board joints do not need to be taped and filled NOTE: Horizontal board joints require minimum 38mm x 63mm C16 timber noggings at board joint	In accordance with BG, Knauf or Siniat fixings requirements Typically, 3.5mm x 38mm self-tapping drywall screws @ maximum 300mm CTRS
INSULATION¹	Optional - for acoustic/thermal purposes, full or partial fill, glass or stone wool insulation NOTE: The addition of mineral wool insulation has no detrimental impact on the fire resistance performance	Friction fitted without fixings
STUDS¹	Minimum 38mm x 89mm C16 CLS timber @ 600mm CTRS NOTE: The addition of studs at closer centres and multiple stud clusters, has no detrimental impact on fire resistance performance	In accordance with structural engineer's fixing requirements Typically, 3.1mm x 88mm twist shank nails, 2 per stud
UNSHEATHED OPTION¹	1 x row 38mm x 89mm C16 CLS timber mid height noggings, staggered NOTE: The addition of mid-height noggings has no detrimental impact on fire resistance performance	In accordance with structural engineer's fixing requirements Typically, 3.1mm x 88mm twist shank nails, 2 per stud/nogging connection
SHEATHED OPTION¹	Minimum 9mm sheathing (OSB/3, plywood or euro-class A1/A2 boarding) NOTE: Sheathing is an optional requirement for structural purposes NOTE: The addition of sheathing has no detrimental impact on fire resistance performance	In accordance with structural engineer's fixing requirements Typically, 2.8mm x 50mm smooth shank nails @ 150mm CTRS (perimeter) and 300mm CTRS (intermediate studs)

6.1 IW60-V-01 REI60 internal wall cont.../

	MATERIAL	FIXING
NOGGINGS¹	Timber ancillary or structural noggings, as required NOTE: <i>The addition of noggings has no detrimental impact on the fire resistance performance</i>	Typically, 3.1mm x 88mm twist shank nails, 2 per stud to nogging
SERVICE PENETRATIONS¹	In accordance with national guidance ² or fire stopped with an EI60 fire tested product to BS EN 1366 for the application or verified by manufacturer's test data for the application	In accordance with the requirements of the fire stopping provision

NOTES:

¹ The designer shall ensure that the wall assembly complies with the Building Regulations, any other relevant statutory guidance and project specification where more onerous for example: structural, acoustic, thermal etc.

² National Statutory Guidance:

- England and Wales: Approved Documents
- Scotland: Technical Handbooks
- Northern Ireland: Technical Booklets

7. Generic party wall systems (REI60)

7.1 PW60-GW-01 REI60 party wall

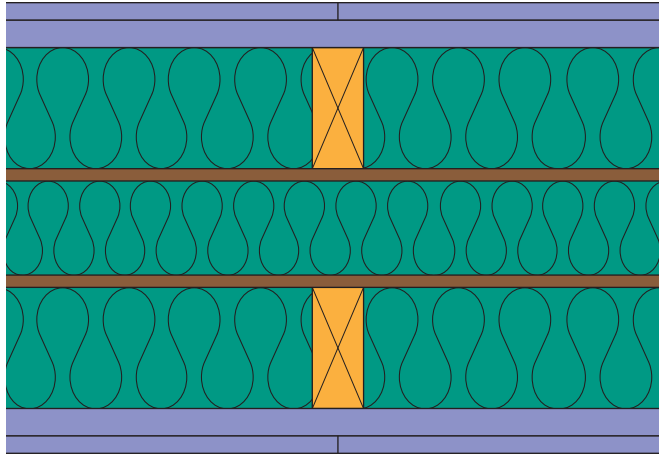

VERIFICATION DETAILS

Based on testing to	BS EN 1365-1:2012 (loaded)
Load applied	100% of in-service design capacity
Limitation	Wall panels up to 3.0m high
3rd party peer review	Milner Associates in collaboration with BRE Global
Robust details	Compliant with EWT-2 insulated cavity
Fire exposure	Each side separately

	MATERIAL	FIXING
ROOM FACE BOTH SIDES ¹	First (outer) layer - 1 x minimum 12.5mm Type A plasterboard. All joints mesh taped and filled NOTE: Plasterboard to have staggered horizontal and vertical joints	In accordance with BG, Knauf or Siniat fixings requirements Typically, 3.5mm x 60mm self-tapping drywall screws @ maximum 300mm CTRS
	Second (inner) layer - 1 x minimum 19mm Type A plasterboard (Gyproc Plank), 600mm x 2400mm fitted horizontally and staggered, no noggings on long edges. The board joints do not need to be taped and filled	In accordance with BG, Knauf or Siniat fixings requirements Typically, 3.5mm x 45mm self-tapping drywall screws @ maximum 300mm CTRS
INSULATION ¹	Studwork - full fill glass or stone wool with thermal conductivity of 0.040 W/mK or lower between studs in each partition	Insulation rolls friction fitted vertically between studs
	Cavity - minimum 50mm with full fill glass or stone wool with thermal conductivity of 0.040 W/mK or lower and minimum density of 17kg/m ³	Insulation rolls friction fitted horizontally in 600mm wide layers and butt jointed
STUDS ¹	2 x 38mm x 89mm C16 CLS timber @ maximum 600mm CTRS in a separated twin leaf formation, with minimum 50mm cavity space between sheathing NOTE: The addition of studs at closer centres and multiple stud clusters, has no detrimental impact on fire resistance performance	In accordance with structural engineer's fixing requirements Typically, 3.1mm x 88mm twist shank nails, 2 per stud

7.1 PW60-GW-01 REI60 party wall cont.../

	MATERIAL	FIXING
UNSHEATHED OPTION¹	<p>1 x row 38mm x 89mm C16 CLS timber mid-height noggings are required</p> <p>NOTE: <i>The addition of mid-height noggings has no detrimental impact on fire resistance performance</i></p>	<p>In accordance with structural engineer's fixing requirements</p> <p>Typically, 3.1mm x 88mm twist shank nails, 2 per stud/nogging connection</p>
SHEATHED OPTION¹	<p>Minimum 9mm sheathing (OSB/3, plywood or euro-class A1/A2 boarding) to cavity faces</p> <p>NOTE: <i>Sheathing can be absent, single sided or double sided (back to back) In accordance with Robust Details wall types E-WT-1 and E-WT-2</i></p> <p>NOTE: <i>The addition of sheathing has no detrimental impact on the fire resistance performance</i></p>	<p>In accordance with structural engineer's fixing requirements</p> <p>Typically, 2.8mm x 50mm smooth shank nails @ 150mm CTRS (perimeter) and 300mm CTRS (intermediate studs)</p>
NOGGINGS	<p>Timber ancillary noggings, as required</p> <p>NOTE: <i>The addition of noggings has no detrimental impact on the fire resistance performance</i></p>	<p>Typically, 3.1mm x 88mm twist shank nails, 2 per stud to nogging</p>
SERVICE PENETRATIONS¹	<p>In accordance with national guidance² or fire stopped with an EI60 fire tested product to BS EN 1366 for the application or verified by manufacturer's test data for the application</p>	<p>In accordance with the requirements of the fire stopping provision</p>

NOTES:

¹ The designer shall ensure that the wall assembly complies with the Building Regulations, any other relevant statutory guidance and project specification where more onerous for example: structural, acoustic, thermal etc.

² National Statutory Guidance:

- England and Wales: Approved Documents
- Scotland: Technical Handbooks
- Northern Ireland: Technical Booklets

7.2 PW60-GW-02 REI60 party wall

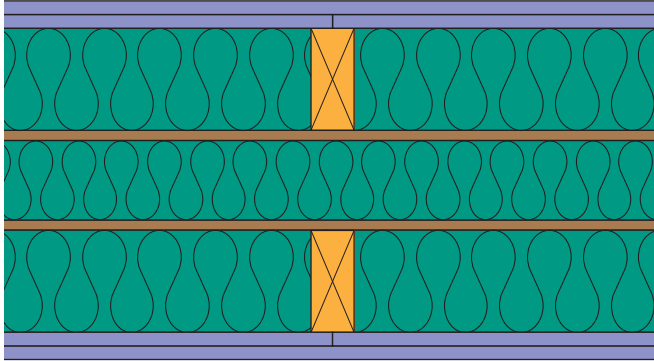

VERIFICATION DETAILS

Based on testing to	BS EN 1365-1 (loaded)
Load applied	100% of in-service design capacity
Limitation	Wall panels up to 3.0m high
3rd party peer review	Milner Associates in collaboration with BRE Global
Fire exposure	Each side separately face

	MATERIAL	FIXING
ROOM FACE BOTH SIDES¹	First (outer) layer - 1 x minimum 15mm Type D ² or F plasterboard. All joints mesh taped and filled NOTE: Plasterboard to have staggered horizontal and vertical joints	In accordance with Knauf or Siniat fixings requirements ² Typically, 3.5mm x 60mm self-tapping drywall screws @ maximum 300mm CTRS
	Second (inner) layer - 1 x minimum 15mm Type A, D ² or F plasterboard. The board joints do not need to be taped and filled NOTE: Horizontal board joints require minimum 38mm x 63mm C16 timber noggings at board joint.	In accordance with Knauf or Siniat fixings requirements ² Typically, 3.5mm x 38mm self-tapping drywall screws @ maximum 300mm CTRS
INSULATION¹	Studwork - full fill glass or stone wool with thermal conductivity of 0.040 W/mK or lower between studs in each partition	Insulation rolls friction fitted vertically between studs
	Cavity - minimum 50mm with full fill glass or stone wool with thermal conductivity of 0.040 W/mK or lower and minimum density of 17kg/m ³	Insulation rolls friction fitted horizontally in 600mm wide layers and butt jointed
STUDS¹	2 x 38mm x 89mm C16 CLS timber @ maximum 600mm CTRS in a separated twin leaf formation, with minimum 50mm cavity space between sheathing NOTE: The addition of studs at closer centres and multiple stud clusters has no detrimental impact on fire resistance performance	In accordance with structural engineer's fixing requirements Typically, 3.1mm x 90mm twist shank nails, 2 per stud
UNSHEATHED OPTION¹	1 x row 38mm x 89mm C16 CLS timber mid-height noggings are required NOTE: The addition of mid-height noggings has no detrimental impact on fire resistance performance	In accordance with structural engineer's fixing requirements Typically, 2.8mm x 50mm smooth shank nails @ 150mm CTRS (perimeter) and 300mm CTRS (intermediate studs)

7.2 PW60-GW-02 REI60 party wall cont.../

	MATERIAL	FIXING
SHEATHED OPTION¹	<p>Minimum 9mm sheathing (OSB/3, plywood or euro-class A1/A2 boarding) to cavity faces</p> <p>NOTE: Sheathing can be absent, single sided or double sided (back to back) In accordance with Robust Details wall types E-WT-1 and E-WT-2</p> <p>NOTE: The addition of sheathing has no detrimental impact on the fire resistance performance</p>	<p>In accordance with structural engineer's fixing requirements</p> <p>Typically, 2.8mm x 50mm smooth shank nails @ 150mm CTRS (perimeter) and 300mm CTRS (intermediate studs)</p>
NOGGINGS¹	<p>Timber ancillary or structural noggings, as required</p> <p>NOTE: The addition of noggings has no detrimental impact on the fire resistance performance</p>	<p>Typically, 3.1mm x 90mm twist shank nails, 2 per stud to nogging</p>
SERVICE PENETRATIONS¹	<p>In accordance with national guidance³ or fire stopped with an EI60 fire tested product to BS EN 1366 for the application or verified by manufacturer's test data for the application</p>	<p>In accordance with the requirements of the fire stopping provision</p>

NOTES:

¹ The designer shall ensure that the wall assembly complies with the Building Regulations, any other relevant statutory guidance and project specification where more onerous for example: structural, acoustic, thermal etc.

² Knauf Soundshield Plus or Siniat GTEC dB Board as tested by the STA.

³ National Statutory Guidance:

- England and Wales: Approved Documents
- Scotland: Technical Handbooks
- Northern Ireland: Technical Booklets

8. Generic floor systems (REI30)

8.1 IF30-IJ-V-01 REI30 intermediate floor, i-joint

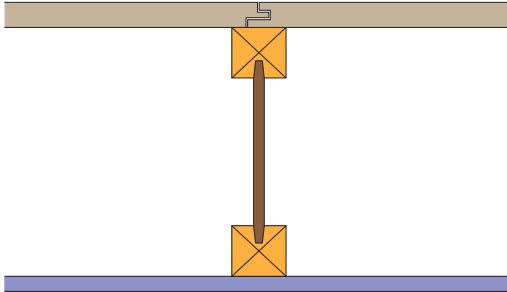

VERIFICATION DETAILS

Based on testing to	BS EN 1365-2 and BS EN 1995-1-2
Load applied	$g_k \leq 0.5^1 \text{kN/m}^2$ excluding partitions ¹ $q_k \leq 1.5 \text{kN/m}^2$ (medium-term), or By calculation based on the stress indices SIM_{fi} and SIV_{fi} (see Part 12 Recommendations on the loading of floors during a fire test)
Verified joists	Staircraft: TFSi-joists
Peer review	Milner Associates in collaboration with BRE Global
Exposure	From underside

	MATERIAL	FIXING
JOISTS²	<p>Minimum 220mm deep proprietary engineered I-joists as listed @ maximum 600mm centres with plasterboard direct fixed to joists</p> <p>Or with suitable resilient bar (e.g. British Gypsum RB1 or Speedline RB565 only) @ maximum 400mm centres to manufacturer's structural design and installation criteria</p> <p>NOTE: Minimum 45mm x 45mm wide strength graded softwood flanges with minimum 11mm thick OSB/4 web</p>	<p>Joists to be supported at the bearing on the bottom flange and fixed in accordance with the manufacturer's instructions</p> <p>Resilient bar, if required, to be fixed to every joist in accordance with the manufacturer's instructions</p>
CEILING LINING²	<p>Minimum 1x 12.5mm gypsum plasterboard Type A or F, with or without board edge noggings/perimeter noggings, with all joints taped and filled</p> <p>Direct fixed to the joists</p> <p>Or fixed to resilient bar as noted in joist section</p> <p>No insulation in floor void included in this peer review/testing</p>	<p>Self-tapping drywall screws fixed in accordance with the manufacturer's instructions @ maximum 230mm centres</p> <p>Ø3.5 x 42mm screws</p> <p>Ø3.5 x 25mm screws</p>

8.1 IF30-IJ-V-01 REI30 intermediate floor, i-joint cont.../

	MATERIAL	FIXING
CEILING PENETRATIONS ²	Downlighters: Maximum 1 no. downlighter ³ per m ² , at least 600mm apart positioned anywhere in the ceiling lining Downlighter as listed by the STA and as tested ³ as part of an REI30 floor assembly to BS EN 1365-2 or as a service penetration with an EI30 fire tested product to BS EN 1366 for the application or verified by manufacturer's test data for the application	In accordance with the manufacturer's instructions
	SVP and mechanical ventilation ducts: In accordance with national guidance ⁴ or fire stopped with an EI30 fire tested product to BS EN 1366 for the application or verified by manufacturer's test data for the application	In accordance with the manufacturer's instructions
	Pendants and detectors: In accordance with national guidance ⁴	
INSULATION ²	Void cavity only	N/A
FLOOR DECK ²	Minimum 18mm T&G wood-based structural flooring (e.g. P5 particleboard, OSB/3 or plywood) T&G deck joints to be glued in accordance with the deck manufacturer's instructions 22mm chipboard is typically expected in domestic floors unless joist centres and acoustics demonstrate otherwise	Typically, Ø2.8 x 65mm threaded nails or Ø4.0 x 60mm screws at 600mm centres with D4 adhesive where verified for the joist type and third-party approved or other equivalent to give the same fixity (not a fire specific dependency)

NOTES:

- ¹ The maximum permitted permanent load excludes the partition load allowance in the accidental fire condition
- ² The designer shall ensure that the floor assembly complies with the Building Regulations, any other relevant statutory guidance and project specification where more onerous for example: structural, acoustic, thermal etc..
- ³ See STA website for document 'Tested downlighters achieving REI30 minutes' for a list of products known to have been tested or assessed as part of an REI30 floor assembly
- ⁴ National Statutory Guidance:
 - England and Wales: Approved Documents
 - Scotland: Technical Handbooks
 - Northern Ireland: Technical Booklets

8.2 IF30-IJ-V-02 REI30 intermediate floor, i-joint

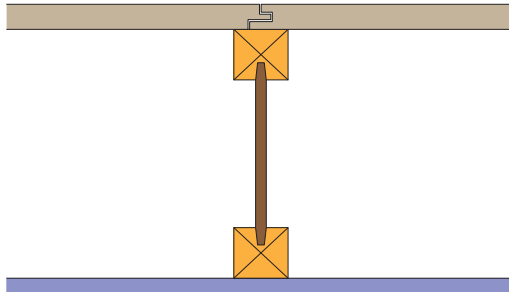

VERIFICATION DETAILS

Based on testing to	BS EN 1365-2 and BS EN 1995-1-2
Load applied	$g_k \leq 0.5^1 \text{kN/m}^2$ excluding partitions ¹ $q_k \leq 1.5 \text{kN/m}^2$ (medium-term), or By calculation based on the Stress Indices SIM_{fi} and SIV_{fi} (see Part 12 Recommendations on the loading of floors during a fire test)
Verified joists	James Jones: JJI-Joists Metsä Wood: Finn-joists Staircraft: TFSi-joists Steico: I-joists
Peer review	Milner Associates in collaboration with BRE Global
Exposure	From underside

	MATERIAL	FIXING
JOISTS¹	<p>Minimum 220mm deep proprietary engineered I-joists as listed @ maximum 600mm centres with plasterboard direct fixed to joists</p> <p>Or with suitable resilient bar (e.g. British Gypsum RB1 or Speedline RB565 only) @ maximum 400mm centres to manufacturer's structural design and installation criteria</p> <p>NOTE: Minimum 45mm x 45mm wide strength graded softwood or 36mm x 45mm wide LVL flanges with minimum 9mm thick OSB/3, OSB/4 or minimum 8mm fibreboard HB.HLA1 web</p>	<p>Joists to be supported at the bearing on the bottom flange and fixed in accordance with the manufacturer's instructions</p> <p>Resilient bar, if required, to be fixed to every joist in accordance with the manufacturer's instructions</p>
CEILING LINING²	<p>Minimum 1x 15mm gypsum plasterboard Type A or F, with or without board edge noggings and perimeter noggings, with all joints taped and filled</p> <p>Direct fixed to the joists</p> <p>Or fixed to resilient bar as noted in joist section</p> <p>No insulation in floor void included in this peer review/testing</p>	<p>Self-tapping drywall screws fixed in accordance with the manufacturer's instructions @ maximum 230mm centres</p> <p>Ø3.5 x 42mm screws</p> <p>Ø3.5 x 25mm screws</p>

8.2 IF30-IJ-V-02 REI30 intermediate floor, i-joint cont.../

	MATERIAL	FIXING
CEILING PENETRATIONS ²	Downlighters: Maximum 1 no. downlighter ³ per m ² , at least 600mm apart positioned anywhere in the ceiling lining Downlighter as listed by the STA and as tested ³ as part of an REI30 floor assembly to BS EN 1365-2 or as a service penetration with an EI30 fire tested product to BS EN 1366 for the application or verified by manufacturer's test data for the application	In accordance with the manufacturer's instructions
	SVP and mechanical ventilation ducts: In accordance with national guidance ³ or fire stopped with an EI30 fire tested product to BS EN 1366 for the application or verified by manufacturer's test data for the application	In accordance with the manufacturer's instructions
	Pendants and detectors: In accordance with national guidance ⁴	
INSULATION ²	Void cavity only	N/A
FLOOR DECK ²	Minimum 18mm T&G wood-based structural flooring (e.g. P5 particleboard, OSB or plywood) T&G deck joints to be glued in accordance with the deck manufacturer's instructions 22mm chipboard is typically expected in domestic floors unless joist centres and acoustics demonstrate otherwise	Typically, Ø4.0 x 60mm screws at 200mm centres without adhesive, or Ø2.8 x 65mm threaded nails or Ø4.0 x 60mm screws at 600mm centres with D4 adhesive or other equivalent to give the same fixity where verified for the joist type and third-party approved (not a fire specific dependency)

NOTES:

- ¹ The maximum permitted permanent load excludes the partition load allowance in the accidental fire condition
- ² The designer shall ensure that the floor assembly complies with the Building Regulations, any other relevant statutory guidance and project specification where more onerous for example: structural, acoustic, thermal etc.
- ³ See STA website for document 'Tested downlighters achieving REI30 minutes' for a list of products known to have been tested or assessed as part of an REI30 floor assembly
- ⁴ National Statutory Guidance:
 - England and Wales: Approved Documents
 - Scotland: Technical Handbooks
 - Northern Ireland: Technical Booklets

8.3 IF30-IJ-V-03 REI30 intermediate floor, i-joint

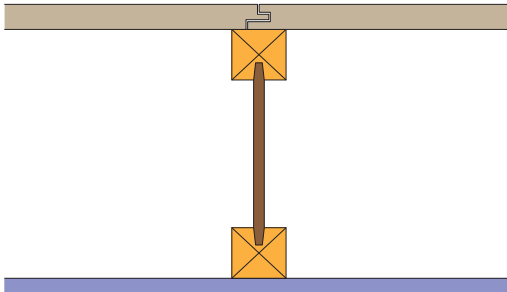

VERIFICATION DETAILS

Based on testing to	BS EN 1365-2 and BS EN 1995-1-2
Load applied	$g_k \leq 0.5^1 \text{kN/m}^2$ excluding partitions ¹ $q_k \leq 1.5 \text{kN/m}^2$ (medium-term), or By calculation based on the Stress Indices SIM_{fi} and SIV_{fi} (see Part 12 Recommendations on the loading of floors during a fire test)
Verified joists	Byggma: Masonite Beams
Peer review	Milner Associates in collaboration with RISE
Exposure	From underside

	MATERIAL	FIXING
JOISTS²	<p>Minimum 220mm deep proprietary engineered I-joists as listed @ maximum 600mm centres with plasterboard direct fixed to joists</p> <p>Or with suitable resilient bar (e.g. British Gypsum RB1 or Speedline RB565 only) @ maximum 400mm centres to manufacturer's structural design and installation criteria</p> <p>NOTE: Minimum 45mm x 45mm wide strength graded softwood or 36mm x 45mm wide LVL flanges with minimum 9mm thick OSB/3, OSB/4</p>	<p>Joists to be supported at the bearing on the bottom flange and fixed in accordance with the manufacturer's instructions</p> <p>Resilient bar, if required, to be fixed to every joist in accordance with the manufacturer's instructions</p>
CEILING LINING¹	<p>Minimum 1x 15mm gypsum plasterboard Type A or F, with or without board edge noggings and perimeter noggings, with all joints taped and filled</p> <p>Direct fixed to the joists</p> <p>Or fixed to resilient bar as noted in joist section</p> <p>No insulation in floor void included in this peer review/testing</p>	<p>Self-tapping drywall screws fixed in accordance with the manufacturer's instructions @ maximum 230mm centres</p> <p>Ø3.5 x 42mm screws</p> <p>Ø3.5 x 25mm screws</p>

8.3 IF30-IJ-V-03 REI30 intermediate floor, i-joint cont.../

	MATERIAL	FIXING
CEILING PENETRATIONS ²	Downlighters: Maximum 1 no. downlighter ³ per m ² , at least 600mm apart positioned anywhere in the ceiling lining Downlighter as listed by the STA and as tested ³ as part of an REI30 floor assembly to BS EN 1365-2 or as a service penetration with an EI30 fire tested product to BS EN 1366 for the application or verified by manufacturer's test data for the application	In accordance with the manufacturer's instructions
	SVP and mechanical ventilation ducts: In accordance with national guidance ³ or fire stopped with an EI30 fire tested product to BS EN 1366 for the application or verified by manufacturer's test data for the application	
	Pendants and detectors: In accordance with national guidance ⁴	
INSULATION ²	Void cavity only	N/A
FLOOR DECK ²	Minimum 18mm T&G wood-based structural flooring (e.g. P5 particleboard, OSB or plywood) T&G deck joints to be glued in accordance with the deck manufacturer's instructions 22mm chipboard is typically expected in domestic floors unless joist centres and acoustics demonstrate otherwise	Typically, Ø4.0 x 60mm screws at 200mm centres without adhesive, or Ø2.8 x 65mm threaded nails or Ø4.0 x 60mm screws at 600mm centres with D4 adhesive and where verified for the joist type and third-party approved or other equivalent to give the same fixity (not a fire specific dependency)

NOTES:

- ¹ The maximum permitted permanent load excludes the partition load allowance in the accidental fire condition
- ² The designer shall ensure that the floor assembly complies with the Building Regulations, any other relevant statutory guidance and project specification where more onerous for example: structural, acoustic, thermal etc.
- ³ See STA website for document 'Tested downlighters achieving REI30 minutes' for a list of products known to have been tested or assessed as part of an REI30 floor assembly
- ⁴ National Statutory Guidance:
 - England and Wales: Approved Documents
 - Scotland: Technical Handbooks
 - Northern Ireland: Technical Booklets

8.4 IF30-MJ-V-01 REI30 intermediate floor, metal web joist

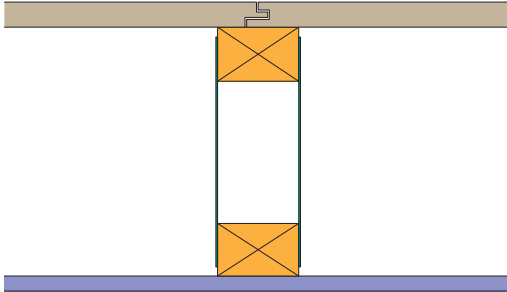

VERIFICATION DETAILS

Based on testing to	BS EN 1365-2 and BS EN 1995-1-2
Load applied	By calculation based on the stress indices SIM_{fi} and SIV_{fi} (see Part 12 Recommendations on the loading of floors during a fire test) excluding partitions ¹
Verified joists	ITW: SpaceJoists Mitek: Posi-Joists Wolf System: easi-Joists®
Peer review	Milner Associates in collaboration with BRE Global
Exposure	From underside

	MATERIAL	FIXING
JOISTS¹	<p>Minimum 219mm deep proprietary engineered metal web joists as listed @ maximum 600mm centres with plasterboard direct fixed to joists</p> <p>Or with suitable resilient bar (e.g. British Gypsum RB1 or Speedline RB565 only) @ maximum 400mm centres to manufacturer's structural design and installation criteria</p> <p>NOTE: Minimum 45mm x 60mm wide strength graded softwood chords with minimum 0.9mm thick steel webs to BS EN 10346</p>	<p>Joists to be supported by bearing on the bottom chord or top-hung. Perimeter details to be designed for the application</p> <p>Strongbacks to be fixed in accordance with the joist manufacturer's instructions</p> <p>Resilient bar, if required, to be fixed to every joist in accordance with the manufacturer's instructions</p>
CEILING LINING¹	<p>Minimum 1x 15mm gypsum plasterboard Type A or F, with or without board edge noggings/perimeter noggings, with all joints taped and filled</p> <p>Direct fixed to the joists</p> <p>Or fixed to resilient bar</p> <p>No insulation in floor void included in this peer review/testing</p>	<p>Self-tapping drywall screws fixed in accordance with the manufacturer's instructions @ maximum 230mm centres</p> <p>Ø3.5 x 42mm screws</p> <p>Ø3.5 x 25mm screws</p>

8.4 IF30-MJ-V-01 REI30 intermediate floor, metal web joist cont.../

	MATERIAL	FIXING
CEILING PENETRATIONS ²	Downlighters: Maximum 1 no. downlighter ² per m ² , at least 600mm apart positioned anywhere in the ceiling lining Downlighter as listed by the STA and as tested ³ as part of an REI30 floor assembly to BS EN 1365-2 or as a service penetration with an EI30 fire tested product to BS EN 1366 for the application or verified by manufacturer's test data for the application	In accordance with the manufacturer's instructions
	SVP and mechanical ventilation ducts: In accordance with national guidance ³ or fire stopped with an EI30 fire tested product to BS EN 1366 for the application or verified by manufacturer's test data for the application	In accordance with the manufacturer's instructions
	Pendants and detectors: In accordance with national guidance ³	
INSULATION ¹	Void cavity only	N/A
FLOOR DECK ¹	Minimum 18mm T&G wood-based structural flooring (e.g. P5 particleboard, OSB or plywood) T&G deck joints to be glued in accordance with the deck manufacturer's instructions 22mm chipboard is typically expected in domestic floors unless joist centres and acoustics demonstrate otherwise	Typically, Ø4.0 x 60mm screws at 200mm centres without adhesive, or Ø2.8 x 65mm threaded nails or Ø4.0 x 60mm screws at 600mm centres with D4 adhesive and where verified for the joist type and third-party approved or other equivalent to give the same fixity (not a fire specific dependency)

NOTES:

- ¹ The maximum permitted permanent load excludes the partition load allowance in the accidental fire condition
- ² The designer shall ensure that the floor assembly complies with the Building Regulations, any other relevant statutory guidance and project specification where more onerous for example: structural, acoustic, thermal etc.
- ³ See STA website for document 'Tested downlighters achieving REI30 minutes' for a list of products known to have been tested or assessed as part of an REI30 floor assembly
- ⁴ National Statutory Guidance:
 - England and Wales: Approved Documents
 - Scotland: Technical Handbooks
 - Northern Ireland: Technical Booklets

9. Generic floor systems (REI60)

9.1 CF60-IJ-GW-01 REI60 compartment floor, i-joist

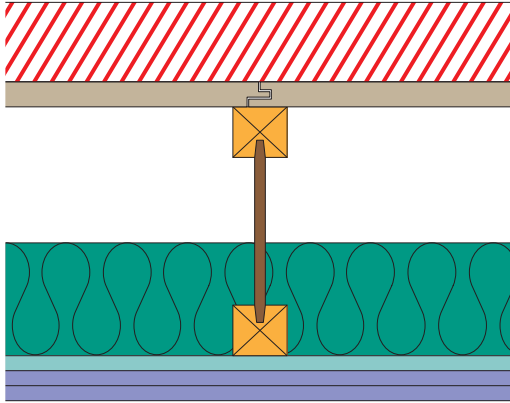

VERIFICATION DETAILS

Based on testing to	BS EN 1365-2 and BS EN 1995-1-2
Load applied	By calculation based on the stress indices $SI_{M'_{fi}}$ and $SI_{V'_{fi}}$ (see Part 12 Recommendations on the loading of floors during a fire test)
Verified joists	James Jones: JJI-Joists Byggma: Masonite Beams Metsä Wood: Finn-joists Staircraft: TFSi-joists Steico: I-joists
Peer review	Milner Associates in collaboration with BRE Global
Exposure	From underside

	MATERIAL	FIXING												
JOISTS¹	<p>Minimum 220mm deep proprietary engineered I-joists @ maximum 600mm centres with a suitable resilient bar (e.g. British Gypsum RB1 or Speedline RB565 only) or minimum 38mm deep x 47mm wide timber battens beneath @ maximum 400mm centres with appropriate fixings</p> <p>Or I-joists @ maximum 400mm centres with plasterboard direct fixed to joists without resilient bar or timber battens</p> <p>NOTE: Minimum 45mm x 45mm wide strength graded softwood or 36mm x 45mm wide LVL flanges with minimum 9mm thick OSB/3, OSB/4 or minimum 9mm fibreboard HB.HLA1 web</p>	<p>Joists to be supported at the bearing on the bottom flange and fixed in accordance with the manufacturer's instructions</p> <p>Perimeter details to avoid bypassing the ceiling lining</p> <p>Resilient bar to be fixed to every joist in accordance with the manufacturer's instructions</p> <p>Battens to be fixed to every joist using screws with a minimum point side penetration of 25mm</p>												
CEILING LINING¹	<p>Minimum 2x 15mm gypsum plasterboard Type F, fixed to every support and additionally fixed around the perimeter of the room; internal unsupported edges permitted perpendicular but not parallel to supports; all joints taped and filled</p> <table border="0"> <tr> <td>Direct fixed to the joists</td> <td>1st layer</td> </tr> <tr> <td></td> <td>2nd layer</td> </tr> <tr> <td>Fixed to resilient bar</td> <td>1st layer</td> </tr> <tr> <td></td> <td>2nd layer</td> </tr> </table>	Direct fixed to the joists	1st layer		2nd layer	Fixed to resilient bar	1st layer		2nd layer	<p>Self-tapping drywall screws fixed in accordance with the manufacturer's instructions @ maximum 230mm centres</p> <table border="0"> <tr> <td>Ø3.5 x 42mm screws</td> </tr> <tr> <td>Ø3.5 x 55mm screws</td> </tr> <tr> <td>Ø3.5 x 25mm screws</td> </tr> <tr> <td>Ø3.5 x 42mm screws</td> </tr> </table>	Ø3.5 x 42mm screws	Ø3.5 x 55mm screws	Ø3.5 x 25mm screws	Ø3.5 x 42mm screws
Direct fixed to the joists	1st layer													
	2nd layer													
Fixed to resilient bar	1st layer													
	2nd layer													
Ø3.5 x 42mm screws														
Ø3.5 x 55mm screws														
Ø3.5 x 25mm screws														
Ø3.5 x 42mm screws														

9.1 CF60-IJ-GW-01 REI60 compartment floor, i-joist cont.../

	MATERIAL	FIXING
CEILING PENETRATIONS ¹	Downlighters: Not permitted. Downlighters can only be installed in a suspended ceiling system that does not form part of the fire resisting assembly	In accordance with the manufacturer's instructions
	SVP and mechanical ventilation ducts: To be boxed in to give equivalent fire performance as the ceiling lining system	In accordance with the manufacturer's instructions
	Pendants and detectors: In accordance with national guidance ²	In accordance with the manufacturer's instructions
INSULATION ¹	Optional - void cavity or limited combustibility stone or glass wool insulation (density: 10-40 kg/m ³)	Insulation to be friction fitted between the joists
FLOOR DECK ¹	Minimum 15mm T&G or square edged wood-based structural flooring (e.g. P5 particleboard, OSB/3 or plywood) to meet the minimum structural requirements of the floor and installed in accordance with the deck manufacturer's instructions Floating floor or other finishes needed to achieve an acoustic floor compliance	Typically, Ø2.8 x 65mm threaded nails or Ø4.0 x 60mm screws at 300mm centres with or without D4 adhesive (not a fire specific dependency ¹) and where verified for the joist type and third-party approved

NOTES:

¹ The designer shall ensure that the floor assembly complies with the Building Regulations, any other relevant statutory guidance and project specification where more onerous for example: structural, acoustic, thermal etc.

² National Statutory Guidance:

- England and Wales: Approved Documents
- Scotland: Technical Handbooks
- Northern Ireland: Technical Booklets

9.2 CF60-MJ-GW-01 REI60 compartment floor, metal web joist

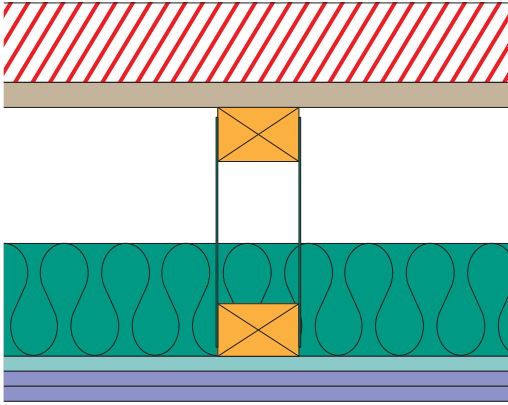

VERIFICATION DETAILS

Based on testing to	BS EN 1365-2 and BS EN 1995-1-2
Load applied	By calculation based on the stress indices $SI_{M'_{fi}}$ and $SI_{V'_{fi}}$ (see Part 12 Recommendations on the loading of floors during a fire test)
Verified joists	ITW: Space Joists Mitek: Posi-Joists Wolf System: Easi-Joists
Peer review	Milner Associates in collaboration with BRE Global
Exposure	From underside

	MATERIAL	FIXING								
JOISTS¹	<p>Minimum 219mm deep proprietary engineered metal web joists @ maximum 600mm centres with a suitable resilient bar (e.g. British Gypsum RB1 or Speedline RB565 only) or minimum 38mm deep x 47mm wide timber battens beneath @ maximum 400mm centres with appropriate fixings</p> <p>Or metal web joists @ maximum 400mm centres with plasterboard direct fixed to joists without resilient bar or battens</p> <p>NOTE: Minimum 45mm x 60mm wide strength graded softwood chords with minimum 0.9mm thick S250-Z275 steel webs to BS EN 10346</p>	<p>Joists to be supported by bearing on the bottom chord or top hung.</p> <p>Perimeter details to avoid bypassing the ceiling lining</p> <p>Strongbacks to be fixed in accordance with the joist manufacturer's instructions</p> <p>Perimeter details to ensure heat does not bypass the ceiling lining</p> <p>Resilient bar to be fixed to every joist in accordance with the manufacturer's instructions</p> <p>Battens to be fixed to every joist using screws with a minimum point side penetration of 25mm</p>								
CEILING LINING¹	<p>Minimum 2x 15mm gypsum plasterboard Type F fixed to every support and additionally fixed around the perimeter of the room; internal unsupported edges permitted perpendicular but not parallel to supports; all joints taped and filled</p> <p>Direct fixed to the joists</p> <table> <tr> <td>1st layer</td> <td></td> </tr> <tr> <td>2nd layer</td> <td></td> </tr> </table> <p>Fixed to resilient bar</p> <table> <tr> <td>1st layer</td> <td></td> </tr> <tr> <td>2nd layer</td> <td></td> </tr> </table>	1st layer		2nd layer		1st layer		2nd layer		<p>Self-tapping drywall screws fixed in accordance with the manufacturer's instructions @ maximum 230mm centres</p> <p>Ø3.5 x 42mm screws Ø3.5 x 55mm screws Ø3.5 x 25mm screws Ø3.5 x 42mm screws</p>
1st layer										
2nd layer										
1st layer										
2nd layer										

9.2 CF60-MJ-GW-01 REI60 compartment floor, metal web joist cont.../

	MATERIAL	FIXING
CEILING PENETRATIONS ¹	Downlighters: Not permitted. Downlighters can only be installed in a suspended ceiling system that does not form part of the fire resisting assembly	In accordance with the manufacturer's instructions
	SVP and mechanical ventilation ducts: To be boxed in to give equivalent fire performance as the ceiling lining system	In accordance with the manufacturer's instructions
	Pendants and detectors: In accordance with national guidance ²	In accordance with the manufacturer's instructions
INSULATION ¹	Optional - void cavity or limited combustibility stone or glass wool insulation (density: 10-40 kg/m ³)	Insulation to be friction fitted between the joists
FLOOR DECK ¹	Minimum 15mm T&G or square edged wood-based structural flooring (e.g. P5 particleboard, OSB/3 or plywood) to meet the minimum structural requirements of the floor and installed in accordance with the deck manufacturer's instructions Floating floor or other finishes needed to achieve an acoustic floor compliance	Typically, Ø2.8 x 65mm threaded nails or Ø4.0 x 60mm screws at 300mm centres with or without D4 adhesive (not a fire specific dependency ¹) and where verified for the joist type and third-party approved

NOTES:

¹ The designer shall ensure that the floor assembly complies with the Building Regulations, any other relevant statutory guidance and project specification where more onerous for example: structural, acoustic, thermal etc.

² National Statutory Guidance:

- England and Wales: Approved Documents
- Scotland: Technical Handbooks
- Northern Ireland: Technical Booklets

10. Generic roof spandrel systems (REI60)

10.1 PWS60-TL-V-01 EI60 party wall spandrel panel with cover strips

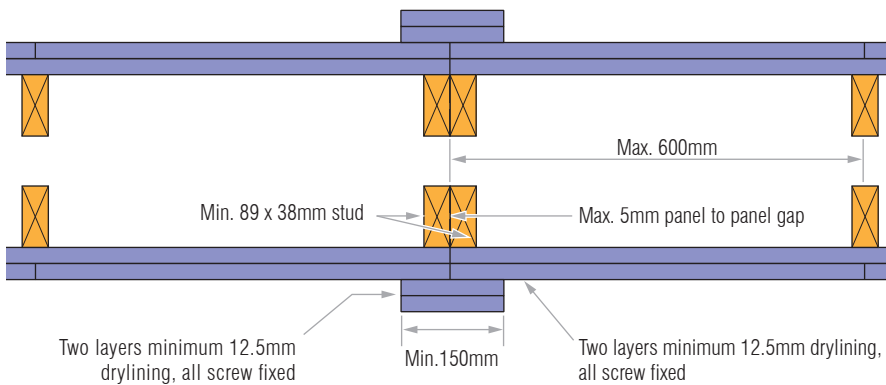

CALCULATED SOLUTION

EI calculated for roofs with ridge no greater than 4m

EI calculated assessment based on EN 1995-1-2:2004 Design of timber structures, Part 1-2, General, Structural fire design

Fire exposure to each side separately

Not part of Milner Associates/BRE Global peer review

	MATERIAL	FIXING
INNER FACE ¹	1 x minimum 12.5mm Type A and F plasterboard fitted and staggered, no horizontal joints	In accordance with BG, Knauf or Siniat fixing requirements Typically, 3.5mm x 38mm self-tapping drywall screws @ maximum 300mm CTRS NOTE: No tape and fill finish at board joints
	Final layer - 1 x minimum 12.5mm Type A and F plasterboard fitted and staggered, no horizontal joints NOTE: All plasterboard sheets to be full height, to avoid horizontal board joint	In accordance with BG, Knauf or Siniat fixing requirements Typically, 3.5mm x 60mm self-tapping drywall screws @ maximum 300mm CTRS NOTE: No tape and fill finish at board joints
PANEL TO PANEL JOINT ¹	2 x minimum 12.5mm x 150mm Type A and F plasterboard cover strips, with staggered joints NOTE: Panel to panel joints can be vertical and horizontal. Cover plates to be butt jointed and staggered over joints	First cover strips - 3.5mm x 38mm self-tapping drywall screws @ maximum 300mm CTRS Final cover strip - 3.5mm x 60mm self-tapping drywall screws @ maximum 300mm CTRS NOTE: No tape and fill finish at cover plate joints
	Panel to panel fixings NOTE: Maximum 5mm permissible tolerance gap at panel to panel abutment. Over clad with plasterboard cover plates	In accordance with structural engineer's fixing requirements Typically, 2.8mm screws @ 300mm CTRS angled at 45 degrees, cross fixed each side, through plasterboards with minimum 25mm timber embedment

* STA have undertaken a non-loadbearing wall test under EN1363-2 external fire curve to reflect the conditions of a fire in a cold roof space which is fully ventilated once the roof has collapsed. Consult with STA Technical for more information

10.1 PWS60-TL-V-01 EI60 party wall spandrel panel with cover strips cont.../

	MATERIAL	FIXING
INSULATION¹	None	N/A
STUDS¹	Minimum 38mm x 89mm C16 CLS timber @ 600mm CTRS	In accordance with structural engineer's fixing requirements Typically, 3.1mm x 88mm twist shank nails, 2 per stud
NOGGINGS¹	Timber ancillary noggings, as required NOTE: The addition of noggings has no detrimental impact on the fire resistance performance	Typically, 3.1mm x 88mm twist shank nails, 2 per stud to nogging

NOTES:

¹ Roof components to meet all other Building Regulation functional requirements or project specification where more onerous: structural, acoustic etc.

10.2 PWS60-TL-V-02 EI60 party wall spandrel panel fire test with intumescent strips

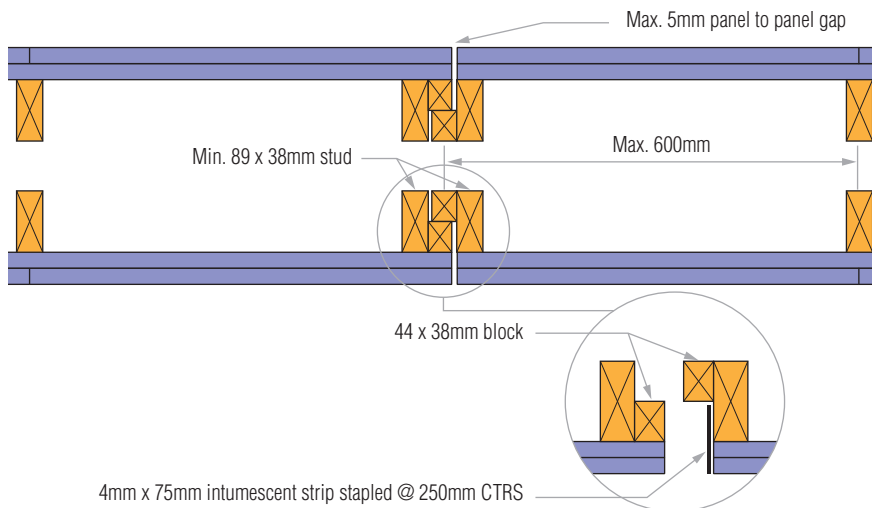

TEST INVESTIGATING PERFORMANCE OF THE JOINT

Cold roof indicative furnace fire test to EN 1363-2 using external fire curve

Two layers of 15mm drylining based on EN 1995-1-2 (2004) verification; Design of timber structures, Part 1-2, General, Structural fire design

Fire exposure to each side separately

Part of the STA fire research programme - presented to provide guidance

Not part of Milner Associates/BRE Global peer review

	MATERIAL	FIXING
INNER FACE ¹	1 x 15mm Type A or F plasterboard fitted and staggered, no horizontal joints	In accordance with BG, Knauf or Siniat fixing requirements Typically, 3.5mm x 38mm self-tapping drywall screws @ maximum 300mm CTRS NOTE: No tape and fill finish at board joints
	Final layer - 1 x 15mm Type A or F plasterboard fitted and staggered, no horizontal joints NOTE: All plasterboard sheets to be full height, to avoid horizontal board joint	In accordance with BG, Knauf or Siniat fixing requirements Typically, 3.5mm x 60mm self-tapping drywall screws @ maximum 300mm CTRS NOTE: No tape and fill finish at board joints

STA have undertaken a non-loadbearing wall test under EN1363-2, reduced fire curve for an external ventilated fire which occurs in a cold roof after the roof has collapsed. Consult with STA Technical for more information

10.2 PWS60-TL-V-02 EI60 party wall spandrel panel fire test with intumescent strips cont.../

	MATERIAL	FIXING
PANEL TO PANEL JOINT ¹	<p>2 x 38mm x 44mm deep, C16 softwood timber batten staggered to each panel end to form Z-joint</p> <p>Minimum 4mm x 75mm intumescent fire seal strip, fitted to one side of joint (Tenmat FF107, open state cavity barrier used in test)</p> <p>NOTE: Maximum 5mm permissible tolerance gap at panel to panel abutment, fire sealed with intumescent strip</p> <p>NOTE: Panel to panel joints can be vertical and horizontal</p>	<p>Typically, 14mm anticorrosion staples @ maximum 250mm CTRS</p> <p>NOTE: Strip to extend full depth of double plasterboard lining and timber batten, so as to be visible once installed</p>
	Panel to panel fixings	<p>In accordance with structural engineer's fixing requirements</p> <p>Typically, 5.8mm x 102mm long screw face fixed at maximum 300mm CTRS, down centre of Z-joint/battens</p> <p>NOTE: No tape and fill or intumescent mastic required at Z-joint plasterboard butt joint</p>
INSULATION ¹	None	N/A
STUDS ¹	Minimum 38mm x 89mm C16 CLS timber @ 600mm CTRS	<p>In accordance with structural engineer's fixing requirements</p> <p>Typically, 3.1mm x 88mm twist shank nails, 2 per stud</p>

NOTES:

¹ Roof components to meet all other Building Regulation functional requirements or project specification where more onerous: structural, acoustic etc.

11. Additional systems

This section provides further information on the additional systems and the guidance available, however it should be noted that the neither the systems or guidance have been part of the Milner Associates/BREGlobal peer review.

11.1 Timber roof truss systems

The Truss Rafter Association (TRA) represents the major engineered metal plate timber roof system suppliers used in the UK. TRA roof truss solutions are applicable to masonry and timber frame construction used in the UK.

Trussed roof systems are commonplace in the UK, reflecting a high degree of uniformity and the generic use of punched metal plate roof truss components, used within their system design criteria.

The new TRA guidance provides builders with design options to meet the fire resistance requirements for trussed rafter ceiling constructions. The construction details on the technical card are shown by test to provide 30 minutes' fire resistance, in line with European Standards. Please contact info@tra.co.uk for further information regarding the guidance.



11.2 Timber wall systems

For the Republic of Ireland marketplace, the Irish Timber Frame Manufacturers Association (ITFMA), in partnership with the Department of Housing and Local Government responsible for building regulations, have undertaken a comprehensive EN fire resistance test programme and have developed their own guidance, endorsed by building regulators.

The technical guidance, available on the Irish Government website, details fire resistance compliance for walls, intermediate floors and trussed roofs in dwellings. **Supplementary Guidance to Technical Guidance Document B (Fire Safety) Volume 2 - Dwelling Houses** is available to download [HERE](#)



12. Supporting appendices

12.1 EN 1365-1:2014 fire resistance testing for walls

Recommendations on the loading of walls during a fire test

Purpose

To provide advice on the procedure to establish the loads used for fire resistance testing of walls to BS EN 1365-1.

Who should read this

Engineers, structural timber building system suppliers, designers, specifiers and product development consultants, with a sound knowledge of product testing and fire design principles.

Historically, fire tests were carried out either for 100% or 60% load ratio, where the 100% load ratio corresponded to the full permissible load that the structural timber element could be stressed to at ambient temperature design. The term load ratio was defined in the withdrawn BS 5269 4.2: Clause 2.3 from 1980 for walls as:

“The ratio of actual axial load to the permissible axial load in a stud in the cold condition, expressed as a percentage.”

A similar definition does not feature in the Eurocode structural design framework. However, the term load ratio or degree of utilisation has a specific, clearly defined, role in structural fire engineering design. It relates to the loads applied at the fire limit state to the resistance at ambient temperature.

When planning a loadbearing wall fire test to BS EN 1365-1 the sponsor of the test must decide what load to apply to the panel to be tested. The guidance in BS EN 1365-1 and BS EN 1363-1 is unclear and open to interpretation.

The STA recommends to suppliers or system developers, that a common approach to loadings should be applied. By doing this, there is a common playing field, where similar products, systems and materials can be tested in a harmonised way, providing confidence to end users, procurement teams, STA members and clients

Loading in fire event (load ratio)

The Eurocodes provide guidance on the reduction of ambient temperature design loading to account for the reduced probability of this load being present during the accidental fire event. This fire load reduction is facilitated by the factor η_{fi} which should not be confused with the load ratio from the former British Standard.

BS EN 1995-1-2 provides a load reduction factor η_{fi} for the accidental fire combination. It is derived from the proportion of imposed load (Q_k) to dead load (G_k) for project-specific application or adopted as a set value of 0.6 for general application and 0.7 for areas susceptible to the accumulation of goods including access areas.

Level of load applied at fire test

The concept of further reducing the load during a fire test could be used in addition to the fire load reduction factor as it has merits for commercial advantage within products/systems used in distinct markets such as housing. The level of load, related to the utilisation of structural elements, is in normal practice well below 100% of maximum load capacity.

For example, a dry lining and insulation type assembly may be chosen to be tested at 60% or 80% load level typical for two-storey house walls. However, the maximum load on the wall would be limited to that maximum utilisation ratio.

The level of load discussed above is comparable to the load ratio according to BS 5268-4.2, historically used for fire testing to BS 476-21. Typical utilisation ratios for walls in residential development:

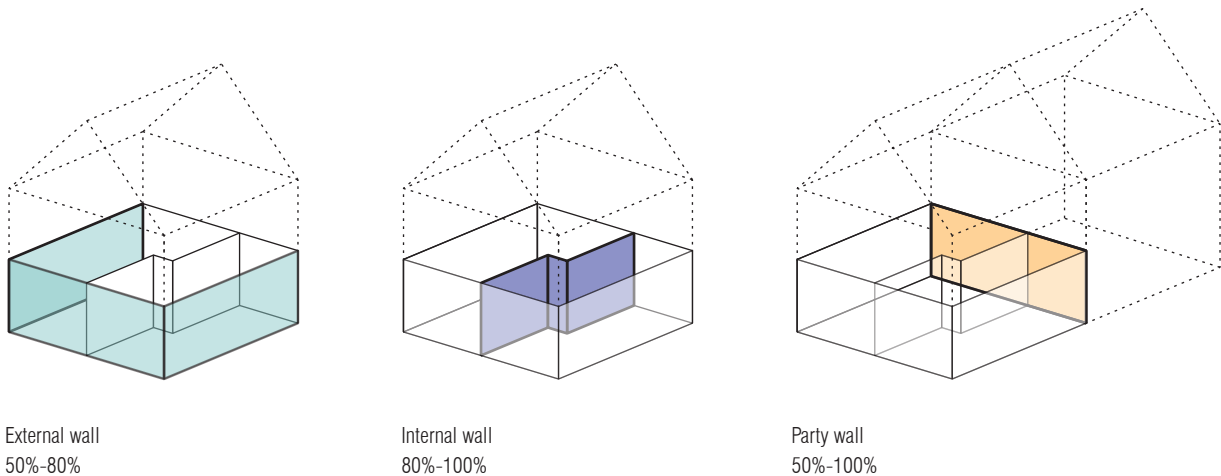

STA recommended approach

Establishing the magnitude of the structural load for EN fire test; to convert the ultimate limit design load for structural strength into the ultimate limit design load during the accidental fire event, the STA recommends the characteristic capacity of the element is multiplied by the appropriate load reduction factor η_i and the medium-term load duration factor K_{mod} and then divided by the material modification factor γ_M .

For general application, the ultimate limit design load for the accidental fire event should be the load applied to the loadbearing wall assembly during the fire test.

A test load should consider the relevant limitations of the assembly, e.g. axial compression of a stud and compression perpendicular to grain at the stud bearing. An indicative procedure is outlined in Figure 1.

Structural load on wall element for EN fire test

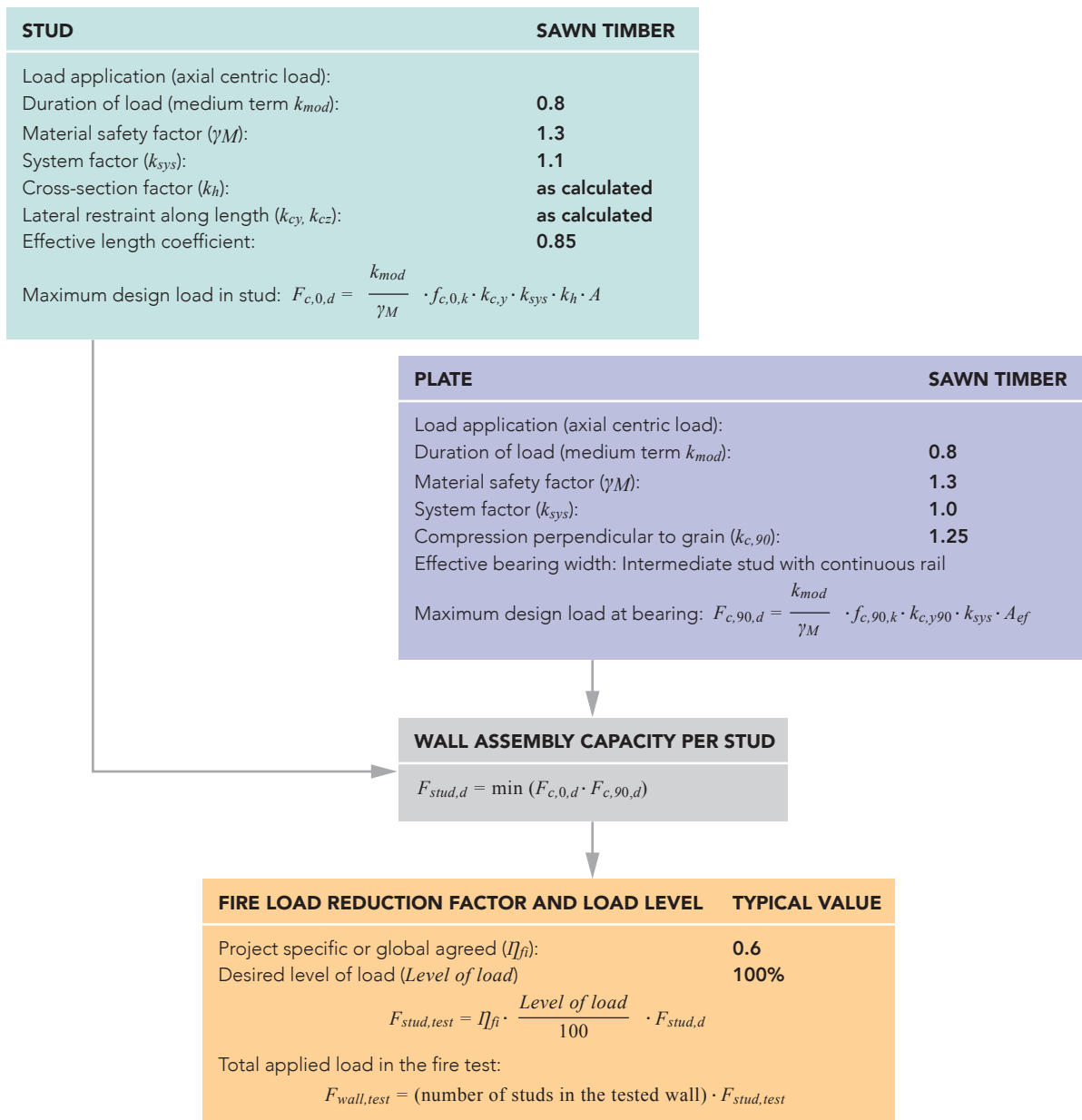

Figure 1: Establishing the magnitude of the structural load for a product assembly in EN fire test

12.2 EN 1365-2:2014 fire resistance testing for floors

Recommendations on the loading of floors during a fire test

Summary

When planning a loadbearing floor fire test to BS EN 1365-2 the sponsor of the test must decide what load to apply to the floor panel to be tested. For generic floor elements, where there is no prior knowledge of the geometry or load, the sponsor must choose a load that will cover the flooring system for the widest range of possible applications. To derive the loading for fire testing, the sponsor should therefore calculate the load which produces the maximum stress levels permissible in the persistent (normal) design situation and reduce them by an appropriate factor in recognition that the fire design situation is an accidental design situation where different factors of safety apply.

Test load for a solid timber joisted floor

The limiting load for a joisted floor system can be calculated as the load that will exceed ULS strength checks according to Eurocode 5. For most floor designs, the strength of the floor will be limited by the bending strength of the timber, but for engineered timber joists there may be other strength verifications that will govern. The uniformly distributed load to be applied to the fire test floor panel can be summarised as the lesser of the bending strength check and the shear strength check:

$$Q_{k, test} = \eta_{fi} \left(M_{Rd} \cdot \frac{8}{s l^2} \right) - G_{k, test} \quad (1)$$

$$Q_{k, test} = \eta_{fi} \left(F_{V,Rd} \cdot \frac{2}{s l} \right) - G_{k, test} \quad (2)$$

Where,

$Q_{k, test}$ = is the load to be applied to the floor test assembly

η_{fi} = is the reduction factor to convert the normal loading to fire loading

M_{Rd} = is the design bending resistance of the joists

$F_{V,Rd}$ = is the design shear resistance of the joists

s = is the spacing of the joists

l = is the span of the joists

$G_{k, test}$ = is the characteristic self-weight of the tested floor assembly

Converting the test load into a limiting load for design

With knowledge of the load that was applied during the fire test, the designer must ensure that the equivalent bending and shear stresses are not exceeded in the normal temperature design in accordance with the direct field of application of BS EN 1365-2:

"The maximum moments and shear forces, which when calculated on the same basis as the test load, shall not be greater than those tested."

The designer can do this by using the stress index. The stress index is defined as the minimum ratio of the applied bending moment and shear force resulting from the applied load. For floor joists the two governing design strength checks are the shear and moment capacity which, for a uniformly distributed load, can be described as:

$SI_{M,fi} = \frac{M_{Ek,test}}{M_{Rk}} = \frac{(G_{k,test} + Q_{k,test})sl^2}{8.M_{Rk}}$	(3)
$SI_{V,fi} = \frac{F_{V,Ek,test}}{F_{V,Rk}} = \frac{(G_{k,test} + Q_{k,test})sl}{2.F_{V,Rk}}$	(4)

Where,

- $SI_{M,fi}$ = the ratio between the bending moment resulting from the load applied to the joist during the test and the characteristic bending strength of the joist
- $SI_{V,fi}$ = the ratio between the design shear force resulting from the load applied to the joist during the test and the characteristic shear strength of the joist
- $M_{Ek,test}$ = the bending moment in the joist resulting from the load applied during the test
- $F_{V,Ek,test}$ = the shear force in the joist resulting from the load applied during the test
- M_{Rk} = the characteristic bending strength of the joist
- $F_{V,Rk}$ = the characteristic shear strength of the joist

The stress index can be considered to be the proportion of the characteristic strength property that can be mobilised in the accidental fire design condition as limited by the load applied during the fire test. The stress index can be used by the designer to verify the accidental design bending and shear capacity of the joist using the equations 5 and 6 respectively:

$\frac{M_{Ed,fi}}{M_{Rd,fi}} = \frac{M_{Ed,fi}}{M_{Rk}SI_{M,fi}} \leq 1.0$	for a UDL:	$\frac{(G_k + \psi_{1,1}Q_k)sl^2}{8.M_{Rk}SI_{M,fi}} \leq 1.0$	(5)
$\frac{F_{V,Ed,fi}}{F_{V,Rd,fi}} = \frac{F_{V,Ed,fi}}{F_{V,Rk}SI_{V,fi}} \leq 1.0$	for a UDL:	$\frac{(G_k + \psi_{1,1}Q_k)sl}{2.F_{V,Rk}SI_{V,fi}} \leq 1.0$	(6)

Where,

- $M_{Rd,fi}$ = is the design bending capacity of the joist limited by fire resistance
- $M_{Ed,fi}$ = is the design bending moment applied to the joists in the accidental design situation
- $F_{V,Rd,fi}$ = is the design shear capacity of the joist limited by fire resistance
- $F_{V,Ed,fi}$ = is the design shear force applied to the joists in the accidental design situation
- G_k = is the characteristic permanent load
- Q_k = is the characteristic variable load
- $\psi_{1,1}$ = is the combination factor for the accidental fire design condition

The fire load reduction factor η_{fi}

The recommended value for the fire load reduction factor $\eta_{fi} = 0.6$ is provided in Note 2 of clause 2.4.2(3) of BS EN 1995-1-2. This value is recommended for all of Europe despite there being significant variation in the self-weight and imposed load on floors, as well as different psi values used to combine actions. In the UK, where there are commonly used floor build-ups and clearly defined imposed load factors and psi values, it can be shown that the reduction factor η_{fi} will rarely be above 0.5.

Taking some common floor build-ups in the UK:

USAGE	G_K	Q_K	Q_K/G_K
Residential	0.50	1.50	3.00
Residential	0.75	1.50	2.00
Flats	1.00	1.50	1.50
Flats	1.25	1.50	1.20
Corridors	0.50	2.50	5.00
Corridors	1.00	2.50	2.50
Plant Room	1.00	4.00	4.00
Load Ratio to achieve = $\eta_{fi} 0.6$	3.00	1.50	0.50

Table 1: Fire load reduction factor η_{fi} for different UK floors

The data given in the above table can be summarised in the following chart:

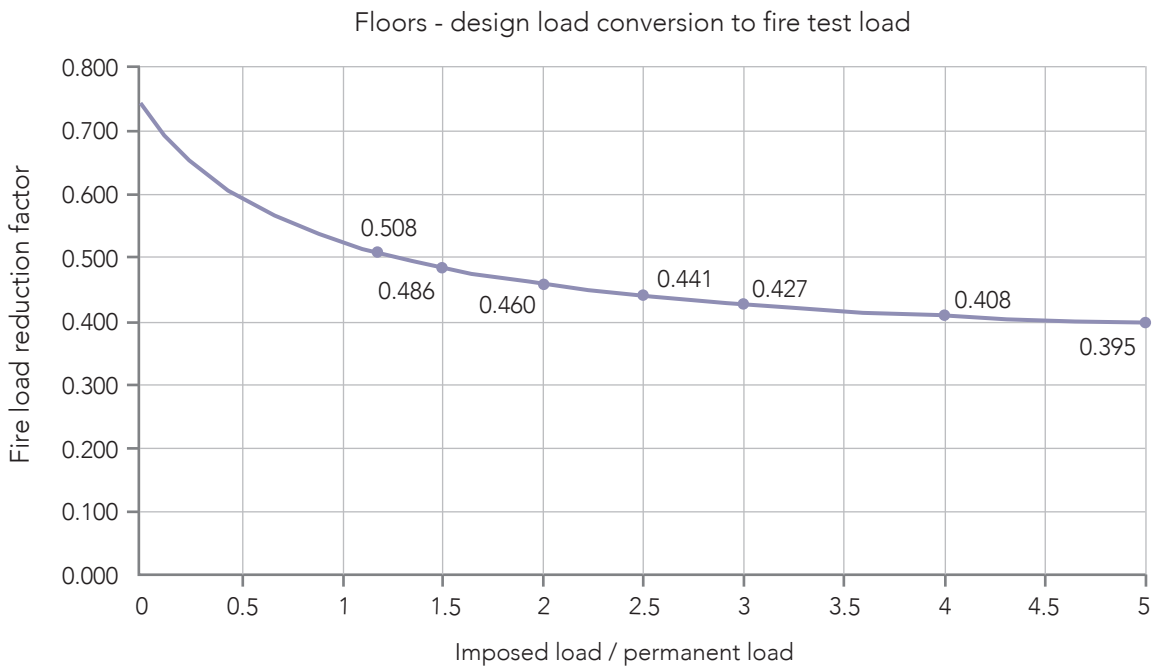
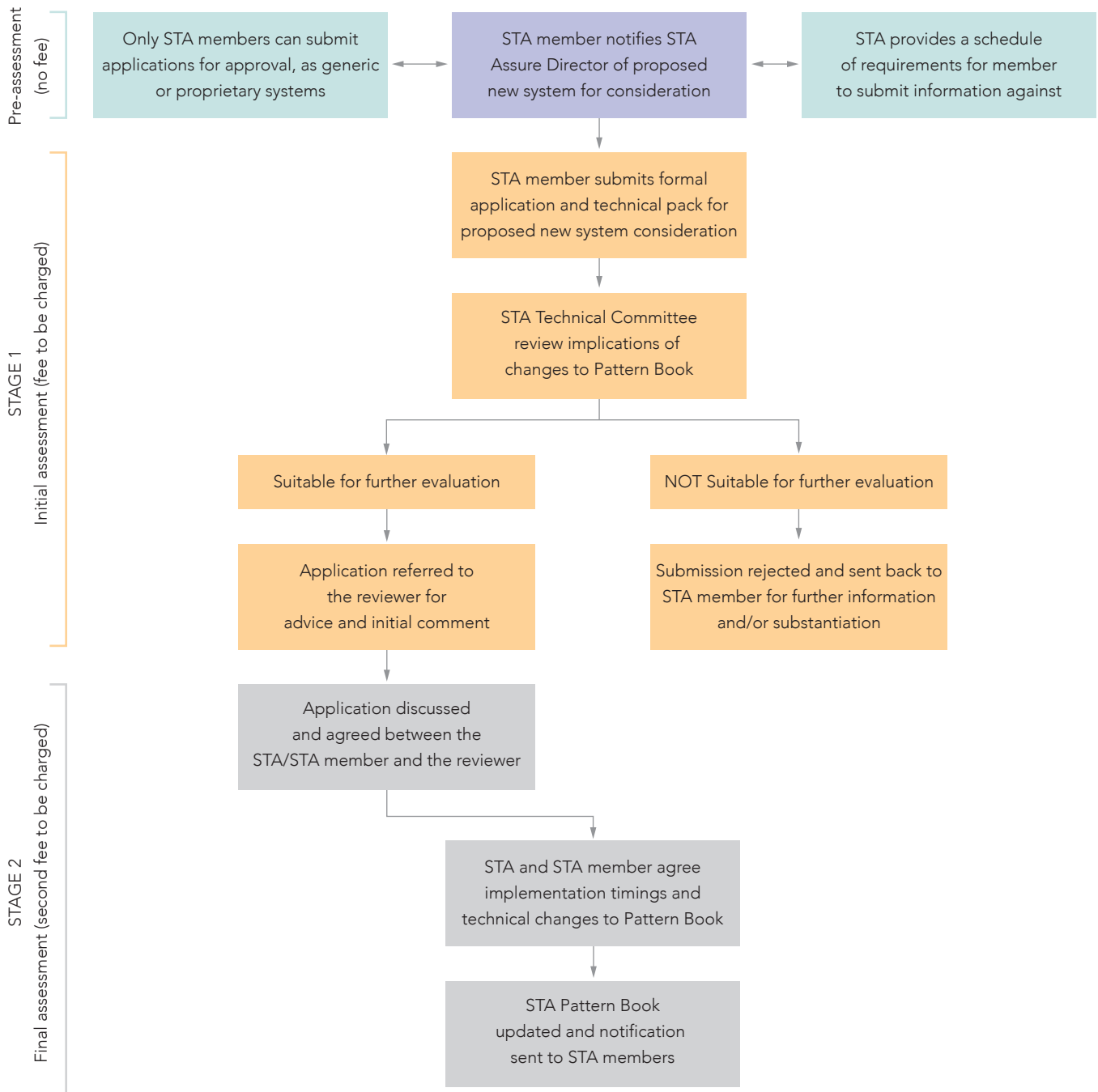

Figure 2: Variation of the fire load reduction factor η_{fi} for different UK floors

Furthermore, it is common for the design of timber floor joists to be limited by serviceability considerations to limit the deflection and vibration performance of the floor. This means that floor joists are rarely stressed to the limit of their strength and the test sponsor may choose to further reduce the load applied to the fire test. However, if the sponsor chooses to reduce the fire test load by stiffness, then the in-service strength of the joists should be limited to ensure that the required fire performance of the floor is achieved in accordance with the direct field of application of the BS EN 1365-2 fire test by the methodology provided above.

12.3 Future systems approvals process flow chart





Head office

Structural Timber Association
The e-Centre
Cooperage Way
Alloa
FK10 3LP

t: 01259 272140

e: office@structuraltimber.co.uk

w: www.structuraltimber.co.uk